



## SA EXAM PAPERS

---

YOUR LEADING PAST YEAR EXAM PAPER  
PORTAL

Visit SA Exam Papers

[www.saexampapers.co.za](http://www.saexampapers.co.za)



# basic education

---

Department:  
Basic Education  
**REPUBLIC OF SOUTH AFRICA**

**NATIONAL  
SENIOR CERTIFICATE**

**GRADE 12**

**CIVIL TECHNOLOGY  
FEBRUARY/MARCH 2017**

**MARKS: 200**

**TIME: 3 hours**

**This question paper consists of 18 pages, 8 answer sheets and a formula sheet.**

**REQUIREMENTS:**

1. Drawing instruments
2. A non-programmable pocket calculator
3. ANSWER BOOK

**INSTRUCTIONS AND INFORMATION**

1. This question paper consists of SIX questions.
2. Answer ALL the questions.
3. Answer each question as a whole. Do NOT separate subsections of questions.
4. Start the answer to EACH question on a NEW page.
5. Do NOT write in the margins of the ANSWER BOOK.
6. You may use sketches to illustrate your answers.
7. Write ALL calculations and answers in the ANSWER BOOK or on the attached ANSWER SHEETS.
8. Use the mark allocation as a guide to the length of your answers.
9. Make drawings and sketches in pencil, fully dimensioned and neatly finished off with descriptive titles and notes to conform to the *SANS/SABS Code of Practice for Building Drawings*.
10. For the purpose of this question paper, the size of a brick should be taken as 220 mm x 110 mm x 75 mm.
11. Use your own discretion where dimensions and/or details have been omitted.
12. Answer QUESTIONS 1.8, 2.6, 3.3, 4.4, 5.2, 5.3, 6.1 and 6.2 on the attached ANSWER SHEETS using drawing instruments, where necessary.
13. Write your CENTRE NUMBER and EXAMINATION NUMBER on every ANSWER SHEET and hand them in with your ANSWER BOOK, whether you have used them or not.
14. Due to electronic transfer, drawings in the question paper are NOT to scale.

**QUESTION 1: CONSTRUCTION, SAFETY AND MATERIAL**

Start this question on a NEW page.

1.1 FIGURE 1.1 below shows a building site.



**FIGURE 1.1**

- 1.1.1 Name the safety equipment shown in FIGURE 1.1. (1)
- 1.1.2 Explain the purpose of the safety equipment shown in FIGURE 1.1. (1)
- 1.1.3 Explain under what circumstances it would be necessary to install this safety equipment on a building site. (2)
- 1.2 Name the type of reinforcing material used to strengthen brickwork. (1)
- 1.3 Name TWO types of brick bonds used in the building industry. (2)
- 1.4 Distinguish between a *closer brick* and a *full brick* in terms of size. (1)
- 1.5 Name TWO types of finishing that would be used on a newly plastered kitchen wall. (2)
- 1.6 Motivate why you used ONE of the finishings that you named in QUESTION 1.5. (1)
- 1.7 Distinguish, by means of line diagrams, between the profiles of *corrugated iron sheeting* and *IBR sheeting*. (2)

1.8 FIGURE 1.8 below illustrates an incomplete sectional view of the substructure of a building.

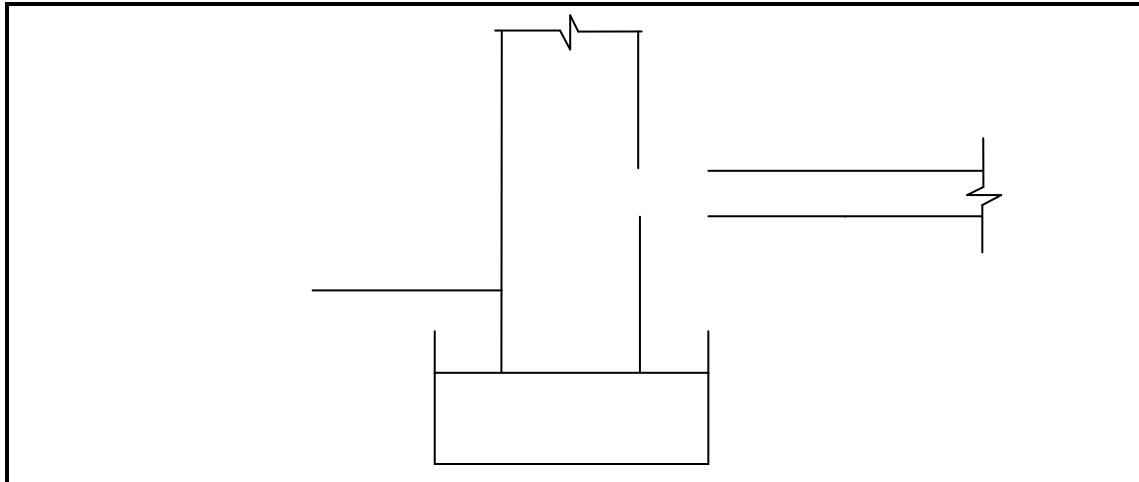

**FIGURE 1.8**

Use ANSWER SHEET 1.8 to complete the sketch by drawing the following:

- Concrete floor penetrating the one-brick wall halfway
- Screed
- Backfilling on both sides
- Blinding layer
- Hardcore filling
- DPC

(10)

1.9 FIGURE 1.9 shows the incomplete top view of a roof layout showing the roof trusses and the outer walls of a rectangular building. Analyse the illustration and answer the questions that follow.

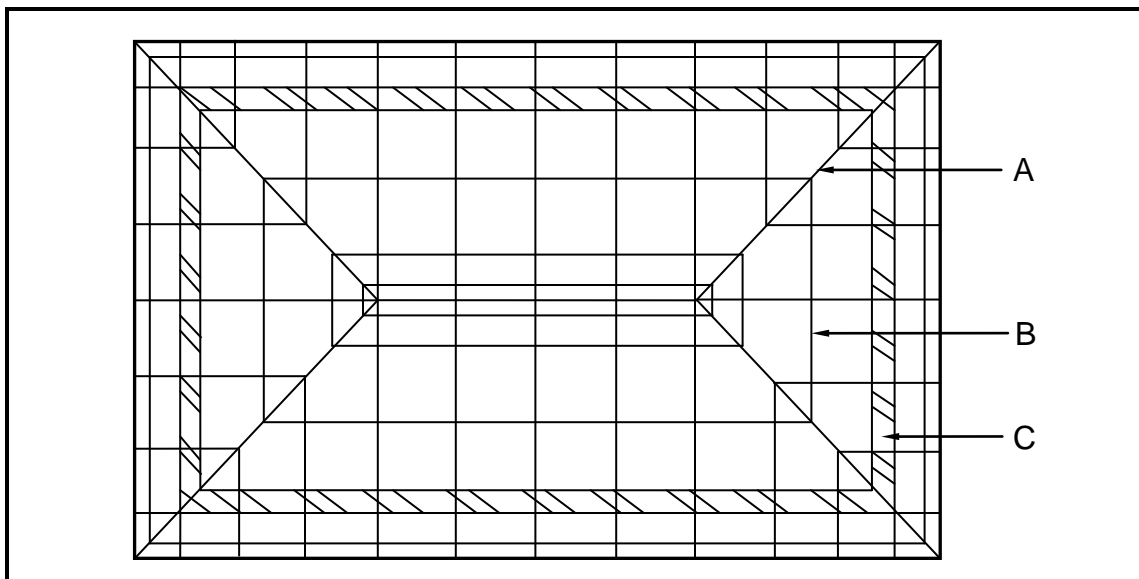

**FIGURE 1.9**

1.9.1 Identify parts **A**, **B** and **C**. (3)

1.9.2 Name the type of roof shown in FIGURE 1.9. (1)

- 1.10 State ONE type of material that DPC may be made of. (1)
- 1.11 Describe TWO requirements that preservatives should comply with to be used effectively on timber. (2)
- [30]**

**QUESTION 2: ADVANCED CONSTRUCTION AND EQUIPMENT**

**Start this question on a NEW page.**

- 2.1 Choose a description from COLUMN B that matches an item in COLUMN A. Write only the letter (A–M) next to the question number (2.1.1–2.1.10) in the ANSWER BOOK, for example 2.1.11 N.

COLUMN A		COLUMN B	
2.1.1	Builder's line	A	part of a pile
2.1.2	Twisted ribbed bar	B	good insulation against heat, cold and sound
2.1.3	Piles	C	erecting scaffolds
2.1.4	Dry wall	D	used as a guide when laying bricks
2.1.5	Plywood	E	allows moisture to escape
2.1.6	Steel casing	F	high-carbon steel
2.1.7	Adhesive fibre-glass mesh (gauze)	G	used for accurate measuring
2.1.8	Weep hole	H	light-weight partition
2.1.9	Dumpy level	I	consists of uneven layers of veneer
2.1.10	Cavity wall	J	used when soil condition is not suitable for normal foundation
		K	consists of even layers of veneer
		L	bonds well with concrete
		M	used to cover and finish off joints where two gypsum boards meet

(10 x 1) (10)

2.2 FIGURE 2.2 below shows hand tools that are used on a site and in a workshop. Write down the correct name of each tool next to the letter (A–C) in the ANSWER BOOK.

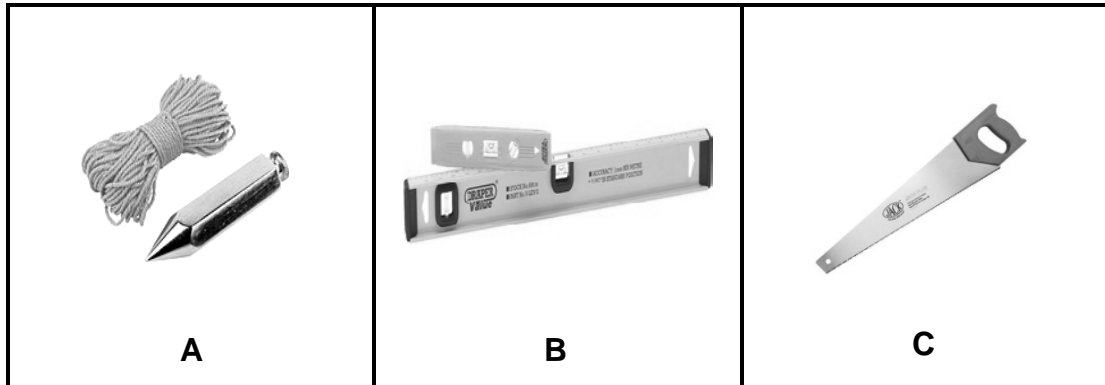

FIGURE 2.2

(3)

2.3 FIGURE 2.3 below shows a construction of the reinforcement of a beam and a column.

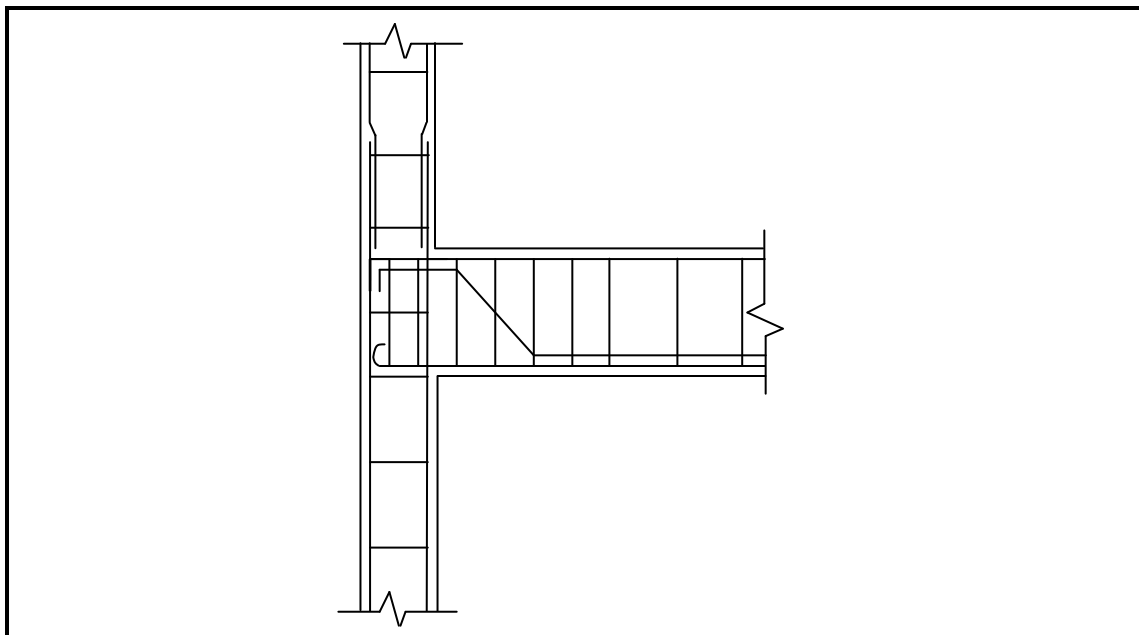

FIGURE 2.3

2.3.1 Name any THREE components used in reinforcement. (3)

2.3.2 What would you use to keep the reinforcement bars away from the formwork when the concrete is being poured? (1)

2.4 Name TWO types of pile foundations. (2)



2.5 FIGURE 2.5 below shows formwork supporting a concrete beam. Analyse the illustration and answer the questions that follow.

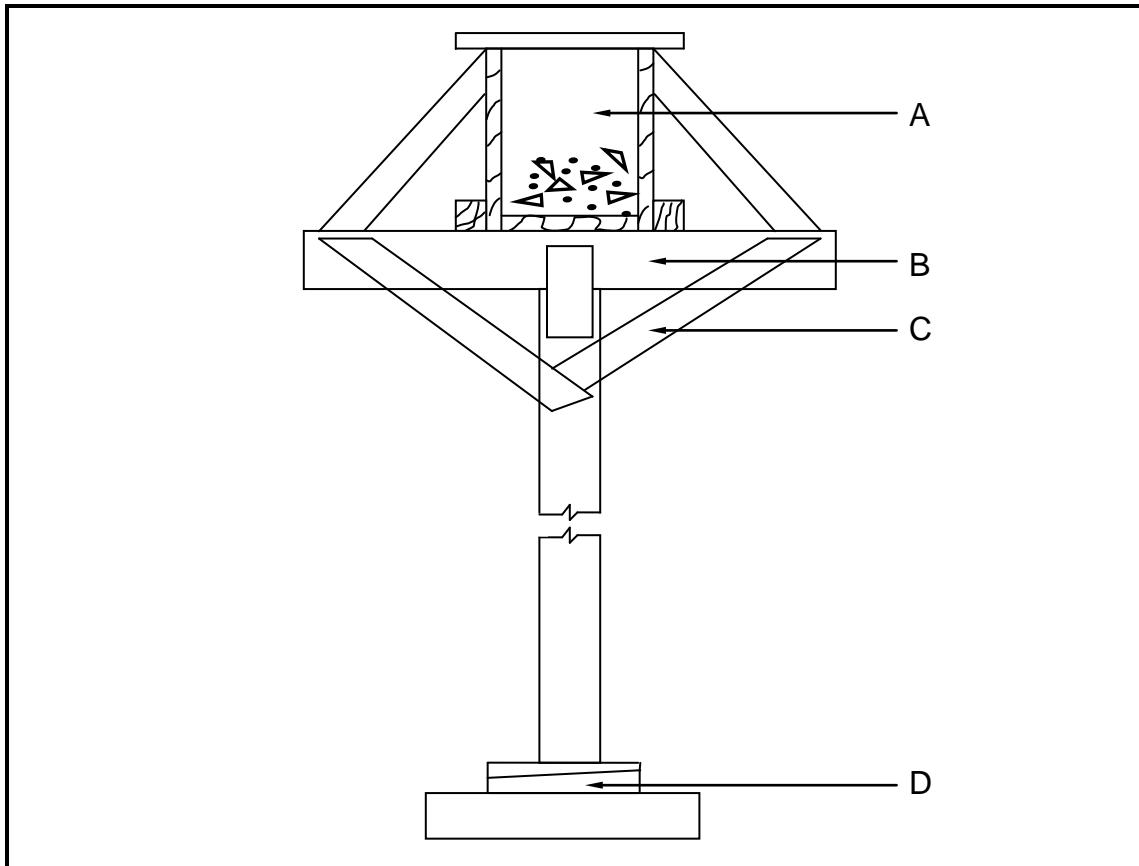

**FIGURE 2.5**

2.5.1 Identify components **A**, **B** and **C**. (3)

2.5.2 Explain TWO functions of component **D**. (2)

2.5.3 Explain the effect that form oils and emulsions, applied to formwork, will have on the concrete. (1)

2.6 Use ANSWER SHEET 2.6 and make a neat sketch, in good proportion, of a vertical section through the bottom part of a steel-frame dry-wall construction.

Show the following details on your sketch:

- Steel floor track fixed to the floor with nylon anchors
- Steel rail with channel facing to the front
- Cladding on one side
- Skirting board on one side
- Label ONE part of the sketch. (6)

- 2.7 Predict ONE consequence/result if concrete is not adequately cured. (1)
- 2.8 If any ONE of the ingredients of concrete were left out, what would be the effect/result? (1)
- 2.9 Draw, in good proportion, a line diagram in the ANSWER BOOK to show the brickwork of a one-brick, semi-circular gauged arch.
- Show THREE bricks of the semi-circular gauged arch as well as the construction showing the method to draw the bricks on the diagram. (2)
  - Label the extrados and intrados of the arch clearly on the diagram. (2)
- 2.10 In terms of cost and labour, explain TWO disadvantages of installing an in situ cast concrete suspended floor instead of a rib and block floor. (2)
- 2.11 Explain ONE reason why you would NOT use a cavity wall as a partition wall inside a building. (1)
- [40]**

**QUESTION 3: CIVIL SERVICES****Start this question on a NEW page.**

- 3.1 Name the fitting that is installed under a wash basin to prevent bad smells from the sewerage system from entering the building. (1)
- 3.2 Explain the function of the *anaerobic bacteria* in a septic tank. (1)
- 3.3 Use ANSWER SHEET 3.3 and draw a line diagram of a septic tank. Show any THREE labels. (7)  
(3)
- 3.4 Define *storm water*. (2)
- 3.5 Explain TWO reasons why sewage should not be directed into a storm-water system. (2)
- 3.6 Explain the purpose of a safety valve, as used in a geyser. (1)
- 3.7 What will happen if the thermostat inside a geyser does not work properly? (1)
- 3.8 Distinguish between a *high-pressure geyser* and a *gravity geyser* in terms of the incoming water supply. (2)
- 3.9 Motivate why black paint is used to paint the inside of the tray of a solar panel. (1)
- 3.10 Draw the symbols for the following:
- 3.10.1 One-way double-pole switch (2)
- 3.10.2 Two-way switch (2)
- 3.10.3 Water meter (2)
- 3.11 Distinguish between the placement of an *elbow* and the placement of a *tee-coupler/T-fitting*, as used in cold-water installation. (2)
- 3.12 State ONE negative result if a pressure-reducing valve is not installed on the cold-water supply of a building. (1)

**[30]**

**QUESTION 4: QUANTITIES, MATERIALS AND JOINING**

**Start this question on a NEW page.**

4.1 FIGURE 4.1 below shows the front view of a single casement with two window panes. The tenons of all the joints are through and through. The horns on both sides are 25 mm long. Study the drawing and use the information to complete the cutting list. Write down the answer next to the question number (4.1.1 to 4.1.8) in the ANSWER BOOK.

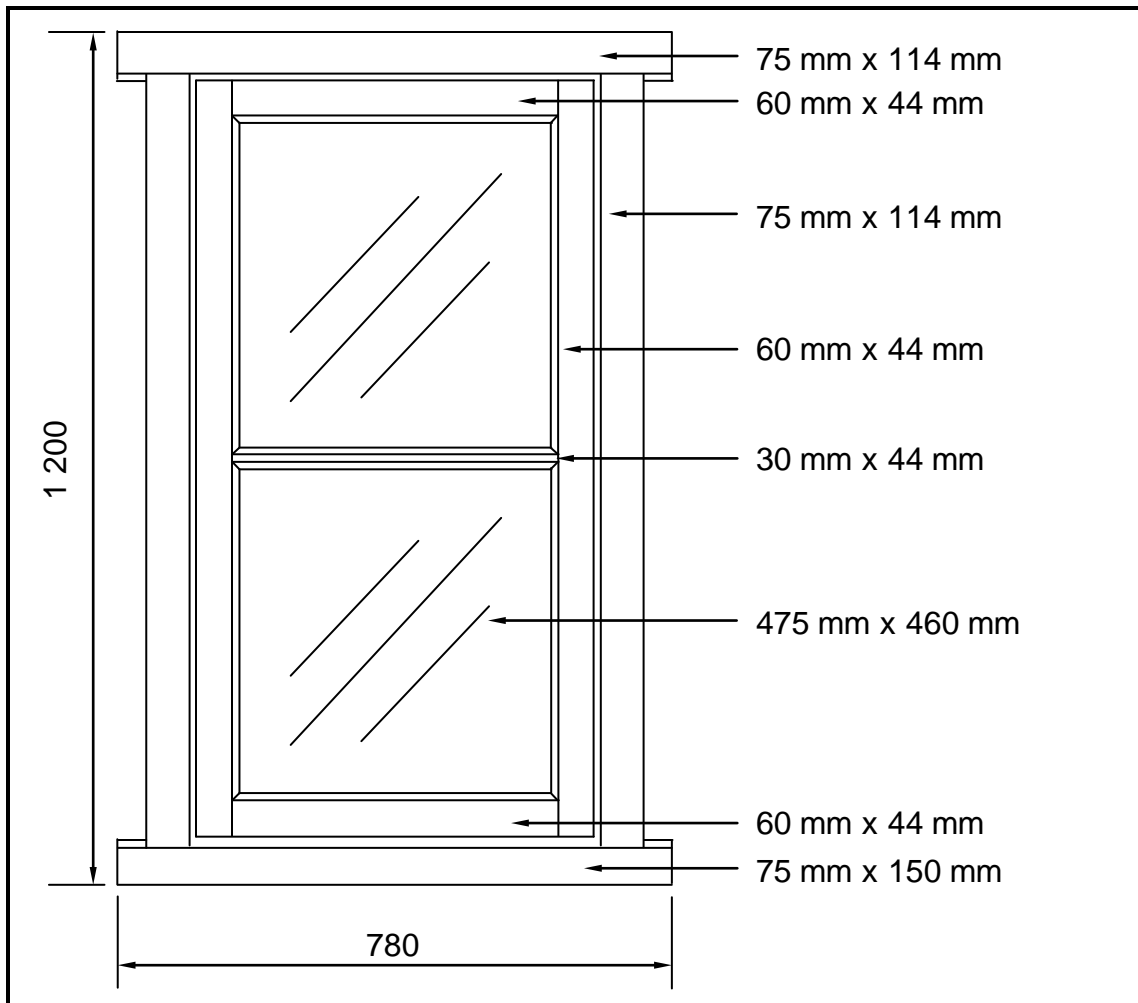

**FIGURE 4.1**

MEMBER	QUANTITY	4.1.1	LENGTH	WIDTH	THICKNESS	MATERIAL
Frame head	1	mm	<b>4.1.2</b>	114	75	Meranti
Sash top rail	1	mm	580	60	<b>4.1.3</b>	Meranti
Frame stile	<b>4.1.4</b>	mm	1 200	114	75	Meranti
Sash stile	2	mm	1 050	<b>4.1.5</b>	44	Meranti
Glazing bar	1	mm	<b>4.1.6</b>	30	44	Meranti
<b>4.1.7</b>	1	mm	580	60	44	Meranti
Window sill	1	mm	780	<b>4.1.8</b>	75	Meranti

(8)

- 4.2 Various options are given as possible answers to the following questions. Choose the answer and write only the letter (A–D) next to the question number (4.2.1–4.2.5) in the ANSWER BOOK, for example 4.2.6 C.
- 4.2.1 The main difference between coach screws and other screws, such as drywall screws and round-head screws, is the ...
- A length.
  - B thickness.
  - C head.
  - D strength. (1)
- 4.2.2 ... nails should be used to fix skirting to brickwork.
- A Oval wire
  - B Clout-headed
  - C Wire
  - D Steel (1)
- 4.2.3 ... is used to seal the joint when galvanised fittings are used to join pipes.
- A Silicone sealer
  - B Contact glue
  - C Plumbing tape/Hemp
  - D PVC weld (1)
- 4.2.4 When making a soldered joint, the melted solder is drawn into the joint by a ... action.
- A pushing
  - B pulling
  - C drawing
  - D capillary (1)
- 4.2.5 To secure roof trusses to a wall you may use hoop iron or ...
- A nylon straps.
  - B 4 mm diameter galvanised wire.
  - C screws.
  - D heavy-duty expansion anchor (Rawl bolt). (1)
- 4.3 Name ONE place where a heavy-duty expansion anchor (Rawl bolt) may be used. (1)

4.4 FIGURE 4.4 below shows the floor plan of a storeroom.

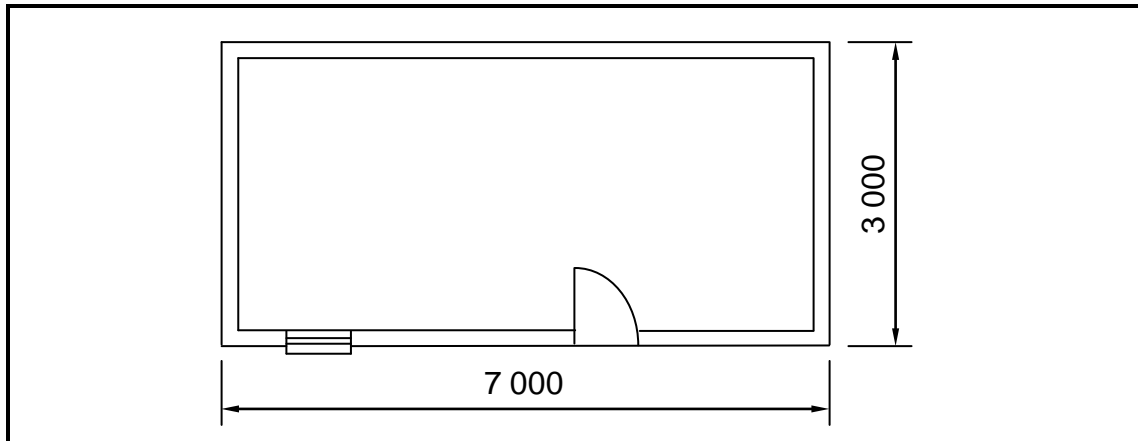

**FIGURE 4.4**

**SPECIFICATIONS:**

- Outside measurements of the storeroom: 7 000 mm x 3 000 mm
- Height of the walls from the finished floor level (FFL) to the wall plate: 2 950 mm
- Thickness of the plaster: 15 mm
- Size of the window: 900 mm x 600 mm
- Size of the door: 2 100 mm x 900 mm

Use ANSWER SHEET 4.4 and calculate:

- 4.4.1 The total outside area of the building that should be plastered from the finished floor level up to the wall plate. Ignore the reveals. (13)
- 4.4.2 The volume of plaster needed for the external walls. Round off your answers to TWO decimals. (3)
- [30]**

**QUESTION 5: APPLIED MECHANICS**

**Start this question on a NEW page.**

- 5.1 FIGURE 5.1 below shows a shaped lamina with an isosceles triangular hole. All dimensions are in millimetres.

Study FIGURE 5.1 and answer the questions by writing only the answer next to the question number (5.1.1–5.1.7) in the ANSWER BOOK, for example 5.1.8 2 900 mm<sup>2</sup>.

**HINT:** Use the formula on the FORMULA SHEET.

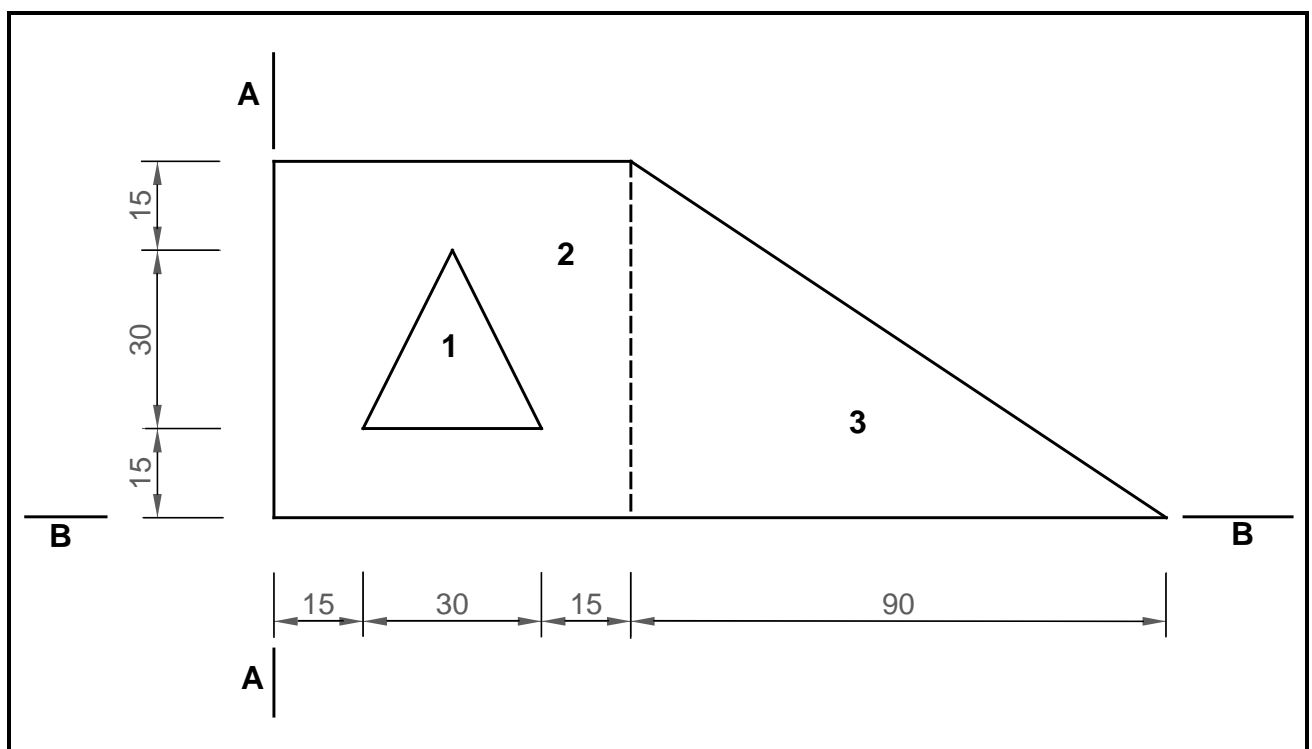

**FIGURE 5.1**

Determine the following:

- |       |   |     |
|-------|---|-----|
| 5.1.1 | Area of part 1                              | (1) |
| 5.1.2 | Area of part 2 without the hole             | (1) |
| 5.1.3 | Area of part 3                              | (1) |
| 5.1.4 | Total area of the lamina                    | (1) |
| 5.1.5 | Position of the centroid of part 1 from A–A | (1) |
| 5.1.6 | Position of the centroid of part 3 from A–A | (2) |
| 5.1.7 | Position of the centroid of part 2 from B–B | (1) |

5.2 ANSWER SHEET 5.2 shows TWO diagrams of a cantilever frame. Use the answer sheet to answer the questions that follow.

5.2.1 Name DIAGRAMS **A** and **B**. Write the answer on the lines provided. (2)

5.2.2 On DIAGRAM **A**, indicate the nature of the forces in each member by means of arrows. (4)

5.2.3 Complete the table by indicating the nature and magnitude of the forces. (Deduce the information from the drawings given.) (6)

5.3 FIGURE 5.3 below shows the space diagram of a beam with a span of 8 metres with two point loads and a uniformly distributed load. Study the diagram and answer the questions that follow.

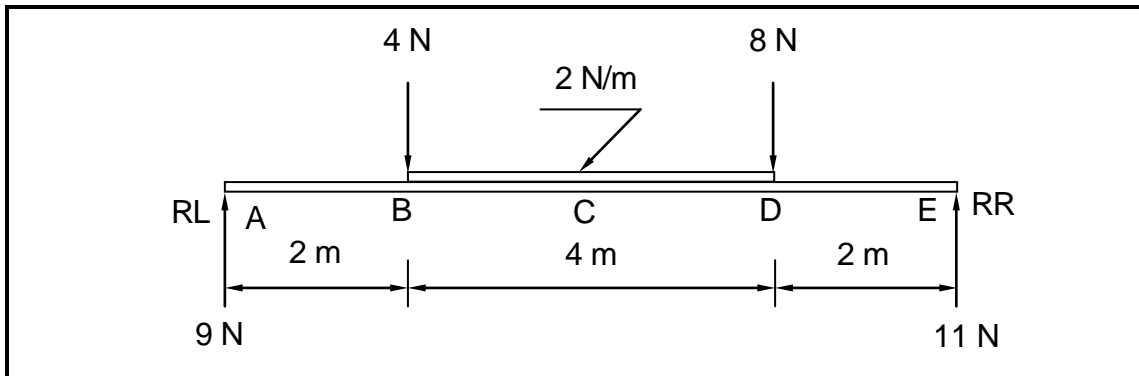

**FIGURE 5.3**

5.3.1 From FIGURE 5.3, deduce the value of the shear forces at **A**, **B**, **D** and **E** and draw the shear force diagram on ANSWER SHEET 5.3. Indicate the value of the shear forces on the diagram. Use scale 5 mm = 1 N. (7)

5.3.2 Calculate the bending moment at **C**. (3)

**[30]**



**QUESTION 6: GRAPHICS AND COMMUNICATION**

6.1 FIGURE 6.1 below shows the SITE PLAN of a proposed dwelling.

Study the drawing and complete the table on ANSWER SHEET 6.1.

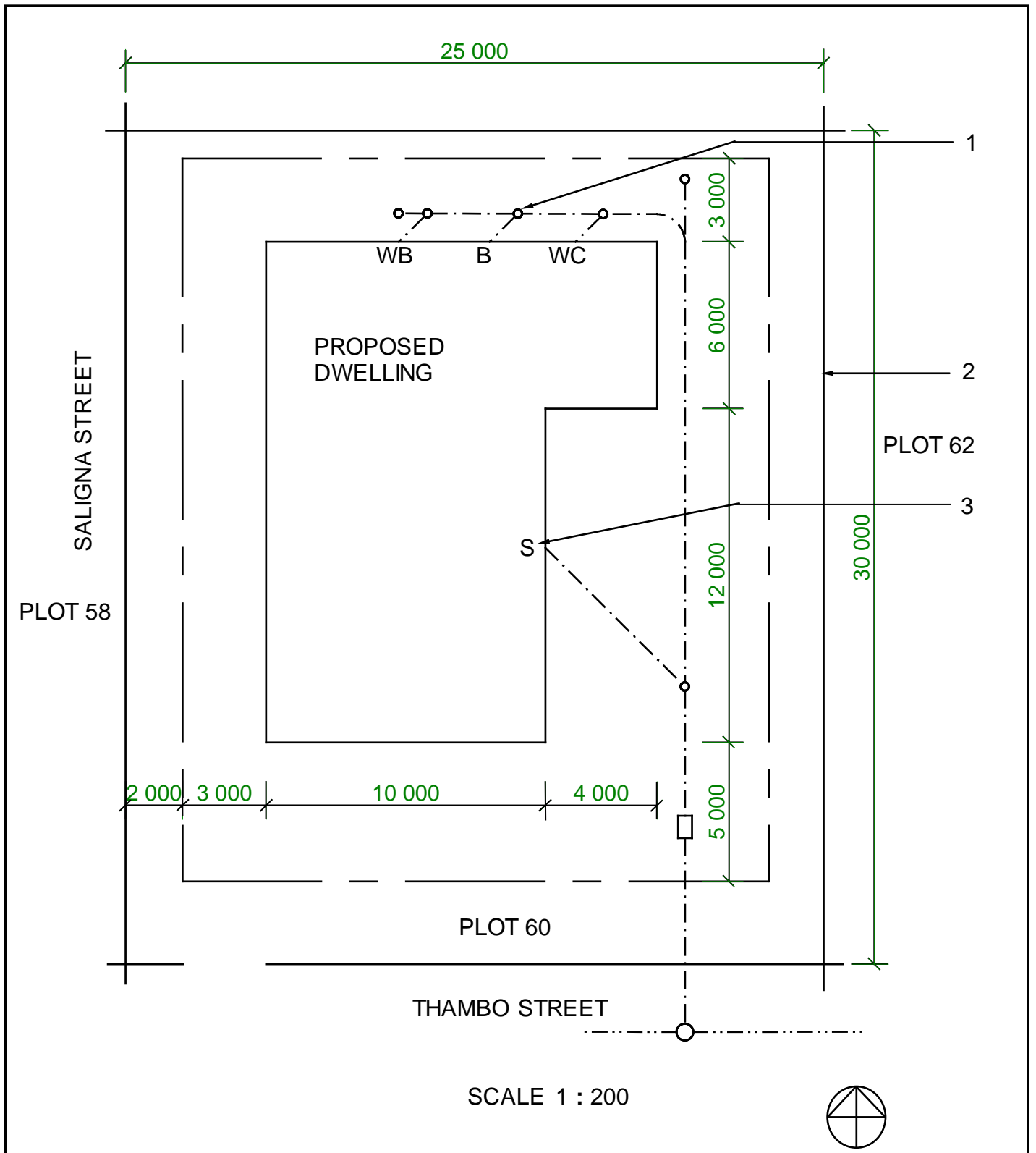

**FIGURE 6.1**

(15)

6.2 FIGURE 6.2 below shows a line diagram of the floor plan of a two-bedroom house.

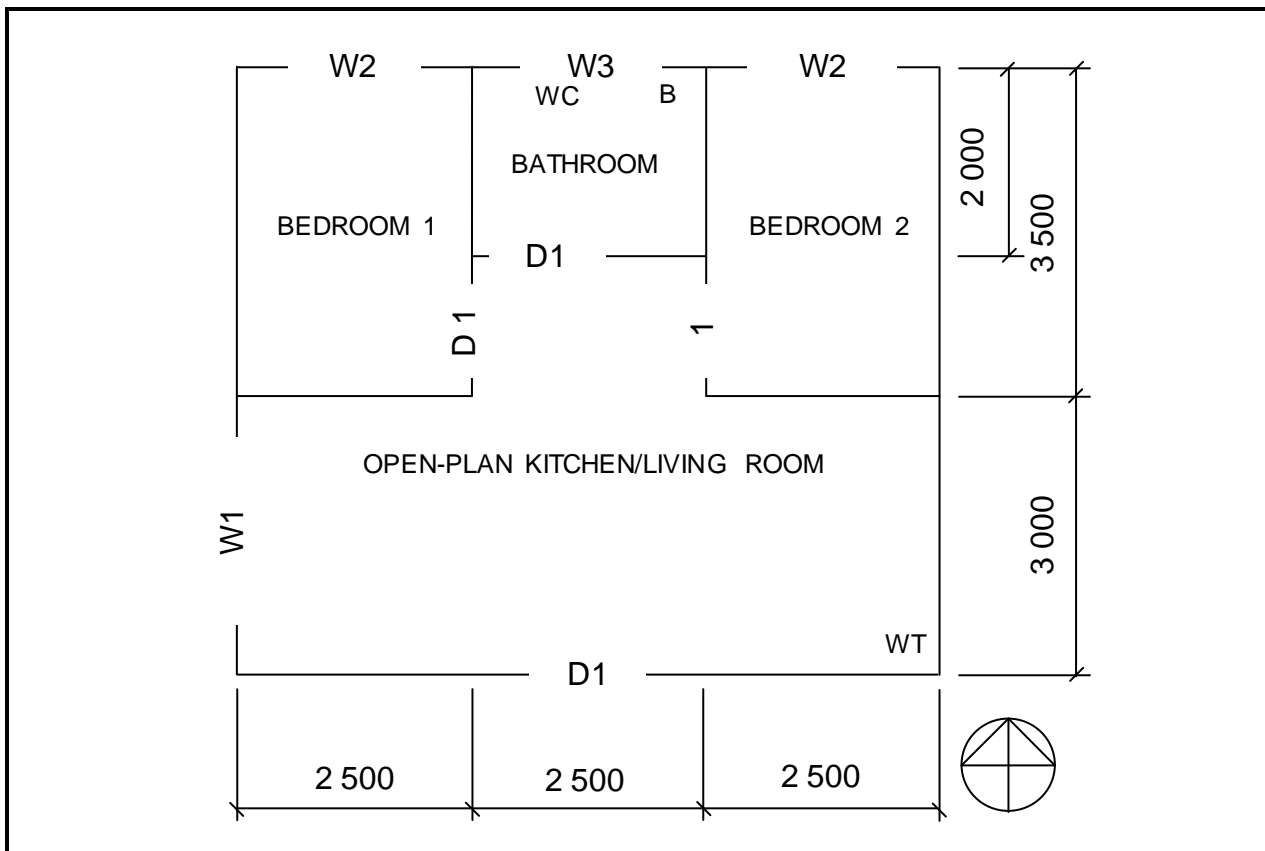

**FIGURE 6.2**

Study FIGURE 6.2 and develop and draw, on ANSWER SHEET 6.2, to scale 1 : 50, the FLOOR PLAN of the building. Use the specifications below and on the next page. (Use the assessment criteria on ANSWER SHEET 6.2 as a guideline for your drawing.)

**SPECIFICATIONS:**

- The measurements indicated on the drawing are the inside measurements of each room.
- Windows and doors:

WINDOWS AND DOORS	WIDTH	HEIGHT
Window 1 (W1)	1 600	1 500
Window 2 (W2)	1 600	1 200
Window 3 (W3)	1 600	900
Door openings 1 (D1)	900	2 100

- All windows are positioned in the middle of the external wall of each room.
- The internal doors are positioned 200 mm from the corner of the wall.
- The front door is positioned in the middle of the wall of the open-plan kitchen/living room.
- All external walls of the house are 220 mm wide.
- All internal walls are 110 mm wide.

Show the following on the drawing:

- The external and internal walls, as well as the windows and doors in the spaces as indicated
- The drawing symbols for a bath and water closet in the bathroom and a wash tub in the open-plan kitchen/living room in the position as indicated on the line diagram
- The overall length of the building on the northern side of the house

THREE marks will be allocated for the application of the scale.

Start the drawing from corner **A**, as indicated in the bottom left-hand corner of ANSWER SHEET 6.2.

(25)  
**[40]**

**TOTAL: 200**

**CENTRE NUMBER:**

--	--	--	--	--	--	--	--	--	--

**EXAMINATION NUMBER:**

--	--	--	--	--	--	--	--	--	--	--	--	--	--	--	--	--	--

**ANSWER SHEET 1.8**

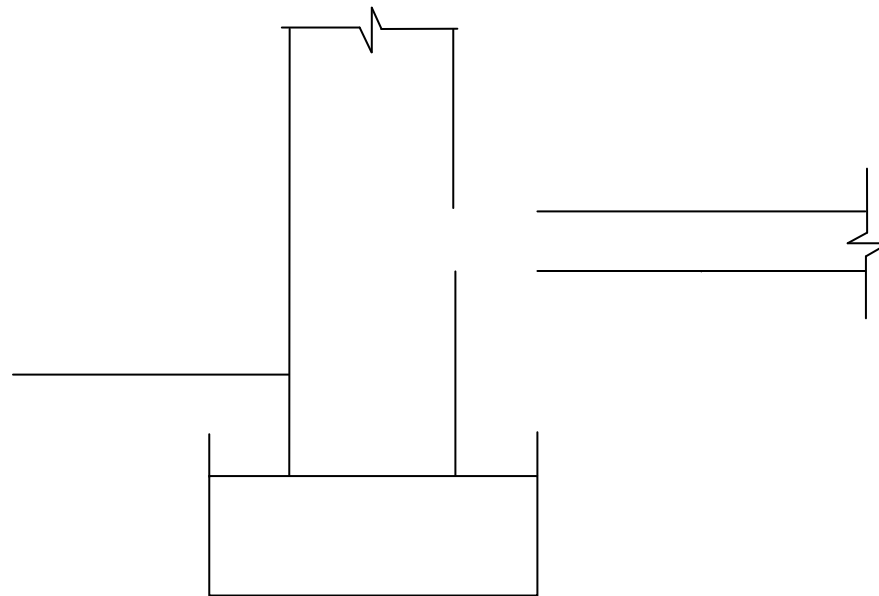

ASSESSMENT CRITERIA	MARK	CANDIDATE'S MARK
Concrete floor drawn in correct place	1	
Screed drawn in correct place	1	
Symbol for screed	1	
Back filling drawn in correct place	2	
Symbol for back filling	1	
Blinding layer drawn in correct place	1	
Hardcore filling drawn in correct place	1	
Symbol for hardcore filling	1	
DPC drawn in correct place	1	
<b>TOTAL</b>	<b>10</b>	

**CENTRE NUMBER:**

**EXAMINATION NUMBER:**

**ANSWER SHEET 2.6**

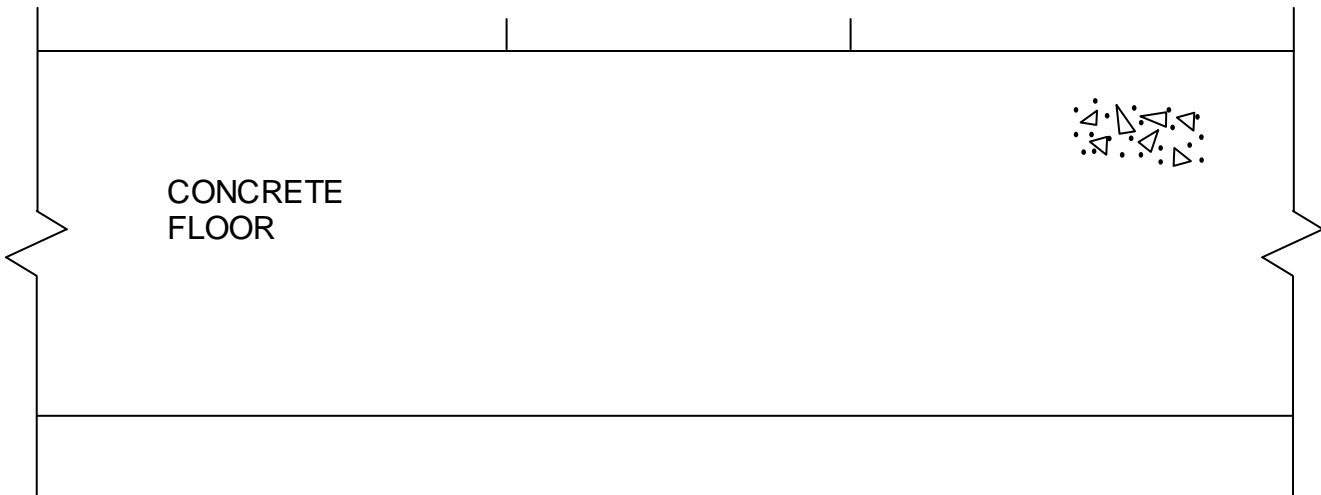

ASSESSMENT CRITERIA	MARK	CANDIDATE'S MARK
Steel floor track	1	
Nylon anchor	1	
Steel rail	1	
Cladding	1	
Skirting board	1	
ONE label	1	
<b>TOTAL</b>	<b>6</b>	

<b>CENTRE NUMBER:</b>										
-----------------------	--	--	--	--	--	--	--	--	--	--

<b>EXAMINATION NUMBER:</b>																			
----------------------------	--	--	--	--	--	--	--	--	--	--	--	--	--	--	--	--	--	--	--

**ANSWER SHEET 3.3**

<b>ASSESSMENT CRITERIA</b>	<b>MARK</b>	<b>CANDIDATE'S MARK</b>
External walls	1	
Inner wall	1	
Opening in inner wall	1	
Concrete base	1	
Inlet and outlet	2	
Cover/Manhole	1	
Any THREE labels	3	
<b>TOTAL</b>	<b>10</b>	

**CENTRE NUMBER:**

--	--	--	--	--	--	--	--	--	--	--	--	--

**EXAMINATION NUMBER:**

--	--	--	--	--	--	--	--	--	--	--	--	--	--	--	--	--	--	--	--	--

**ANSWER SHEET 4.4**

Write your answers in the spaces indicated with \_\_\_\_\_.

4.4.1

A	B	C	D
			<u>Area to be plastered:</u>
			Total outside length of short walls:
			= <u>  2/  </u> mm
			= _____ mm
			Total outside length of long walls:
			= <u>  2/  </u> mm
			= _____ mm
			Total outside length of all the walls:
			= _____ mm + _____ mm
			= _____ mm
1/			Outside area of walls before deductions:
	_____	_____ m <sup>2</sup>	
	_____		
1/			Area of window opening:
	_____	_____ m <sup>2</sup>	
	_____		
1/			Area of door opening:
	_____	_____ m <sup>2</sup>	
	_____		
			Total wall area to be plastered:
			_____ m <sup>2</sup> - _____ m <sup>2</sup> - _____ m <sup>2</sup>
			= _____ m <sup>2</sup>

(3)

(2)

(2)

(2)

(4)

4.4.2

			<u>Volume of plaster needed:</u>
1/	_____		
	_____	_____ m <sup>2</sup>	

(3)

**[16]**

**CENTRE NUMBER:**

--	--	--	--	--	--	--	--	--	--

**EXAMINATION NUMBER:**

--	--	--	--	--	--	--	--	--	--	--	--	--	--	--	--	--	--	--	--

**ANSWER SHEET 5.2**

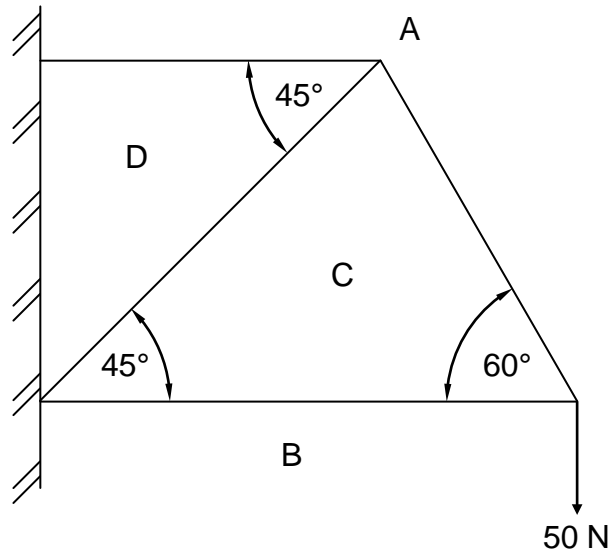

(4)

**DIAGRAM A** \_\_\_\_\_

(1)

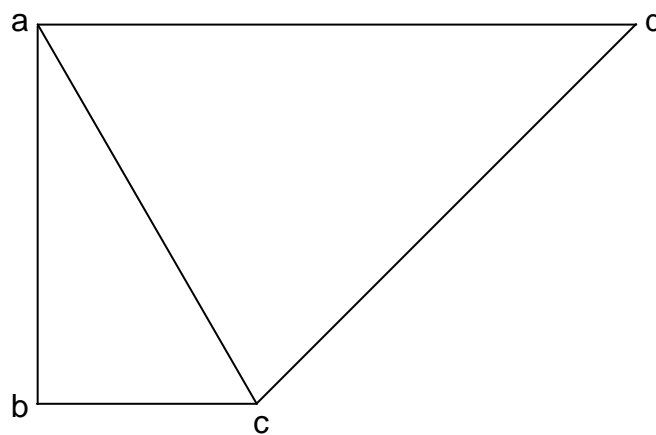

**DIAGRAM B** \_\_\_\_\_

(1)

**SCALE 1 mm = 1 N**

MEMBER	NATURE	MAGNITUDE
AC		
BC		---
CD		
DA		---

(6)

Tolerance of 1 N to either side



**CENTRE NUMBER:**

--	--	--	--	--	--	--	--	--	--

**EXAMINATION NUMBER:**

--	--	--	--	--	--	--	--	--	--	--	--	--	--	--	--	--	--	--	--

**ANSWER SHEET 5.3**

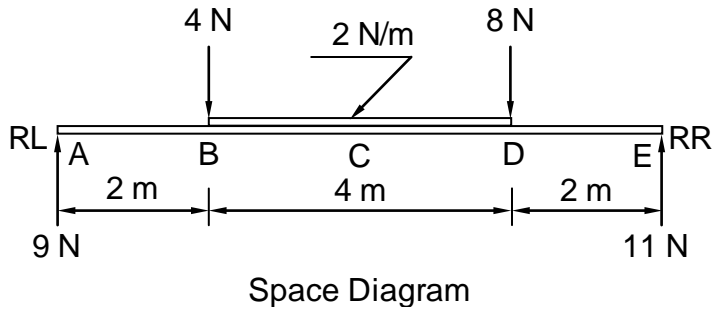



**SCALE 5 mm = 1 N**

ASSESSMENT CRITERIA	MARKS	CANDIDATE'S MARKS
Drawing correct	5	
Indicate four or more values of shear forces on drawing	1	
Correct application of scale	1	
<b>TOTAL</b>	<b>7</b>	

<b>CENTRE NUMBER:</b>										
-----------------------	--	--	--	--	--	--	--	--	--	--

<b>EXAMINATION NUMBER:</b>															
----------------------------	--	--	--	--	--	--	--	--	--	--	--	--	--	--	--

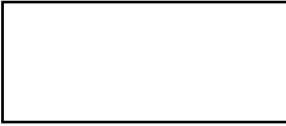
**ANSWER SHEET 6.1**

<b>NO.</b>	<b>QUESTIONS</b>	<b>ANSWERS</b>	<b>MARKS</b>
1	Name the scale used for the site plan.		1
2	Name the colour that you would use to shade the proposed dwelling on a site plan.		1
3	Identify number 1.		1
4	What is the number of the plot on which the house will be built?		1
5	Describe abbreviation 3.		1
6	Determine the distance from the boundary line to the proposed dwelling on the western side of the building.		1
7	Determine the distance between the building line and the building on the northern side of the building.		1
8	In which street is the entrance to the site located?		1
9	Draw the roof line of a gable roof for the building indicated in the column alongside.		3
10	Calculate the total area of the building in square metres.		2
11	If the area of the site is 750 m <sup>2</sup> , what percentage will the building occupy on the site: 29,2% <b>OR</b> 27,2% <b>OR</b> 25,2%?		2
		<b>TOTAL</b>	<b>15</b>

**CENTRE NUMBER:**

**EXAMINATION NUMBER:**

### ANSWER SHEET 6.2

ASSESSMENT CRITERIA	MARKS	LM	ASSESSMENT CRITERIA	MARKS	LM
External walls	4		Bath	1	
Internal walls	5		Dimensions	2	
Windows	4		<b>Application of scale</b> One or two incorrect = 3 Three or four incorrect = 2 More than five incorrect = 1 No measurement correct = 0	3	
Doors	4				
Wash tub	1				
Water closet	1				
<b>TOTAL</b>			<b>25</b>		



**FORMULA SHEET****IMPORTANT ABBREVIATIONS**

SYMBOL	DESCRIPTION	SYMBOL	DESCRIPTION	SYMBOL	DESCRIPTION
c	Centroid	b	Breadth/Width	r	Radius
l	Length	s	Side	A	Area

**FORMULAE**

AREA OF	FORMULA (in words)	FORMULA (In symbols)	FORMULA FOR THE POSITION OF CENTROIDS	
			X-axis	Y-axis
Square	side x side	s x s	$\frac{s}{2}$	$\frac{s}{2}$
Rectangle	length x breadth	l x b	$\frac{l}{2}$	$\frac{b}{2}$
Right-angled triangle	$\frac{1}{2}$ x base x height	$\frac{1}{2}$ b x h	$\frac{b}{3}$	$\frac{h}{3}$
Equilateral triangle/ Isosceles triangle	$\frac{1}{2}$ x base x height	$\frac{1}{2}$ b x h	$\frac{b}{2}$	$\frac{h}{3}$

$$\text{Position of centroid} = \frac{(A1 \times d) \pm (A2 \times d)}{\text{Total area}}$$

**OR**

$$Y = \frac{\sum Ay}{\sum A}$$

**OR**

$$X = \frac{\sum Ax}{\sum A}$$