



## SA EXAM PAPERS

---

YOUR LEADING PAST YEAR EXAM PAPER  
PORTAL

Visit SA Exam Papers

[www.saexampapers.co.za](http://www.saexampapers.co.za)



# basic education

---

Department:  
Basic Education  
**REPUBLIC OF SOUTH AFRICA**

## **NATIONAL SENIOR CERTIFICATE**

**GRADE 12**

**CIVIL TECHNOLOGY**  
**FEBRUARY/MARCH 2015**

**MARKS: 200**

**TIME: 3 hours**

**This question paper consists of 18 pages, 6 answer sheets and a formula sheet.**

**REQUIREMENTS:**

1. Drawing instruments
2. A non-programmable pocket calculator
3. ANSWER BOOK

**INSTRUCTIONS AND INFORMATION**

1. This question paper consists of SIX questions.
2. Answer ALL the questions.
3. Answer each question as a whole. Do NOT separate subsections of questions.
4. Start the answer to EACH question on a NEW page.
5. Do NOT write in the margin of the ANSWER BOOK.
6. You may use sketches to illustrate your answers.
7. Write ALL calculations and answers in the ANSWER BOOK or on the attached ANSWER SHEETS.
8. Use the mark allocation as a guide to the length of your answers.
9. Make drawings and sketches in pencil, fully dimensioned and neatly finished off with descriptive titles and notes to conform to the *SANS/SABS Code of Practice for Building Drawings*.
10. For the purpose of this question paper, the size of a brick should be taken as 220 mm x 110 mm x 75 mm.
11. Use your own discretion where dimensions and/or details have been omitted.
12. Answer QUESTIONS 2.7, 4.5, 5.2, 5.3, 6.1 and 6.2 on the attached ANSWER SHEETS using drawing instruments where necessary.
13. Write your CENTRE NUMBER and EXAMINATION NUMBER on every ANSWER SHEET and hand them in with your ANSWER BOOK, whether you have used them or not.
14. Drawings in the question paper are NOT to scale due to electronic transfer.

**QUESTION 1: CONSTRUCTION, SAFETY AND MATERIAL**

- 1.1 FIGURE 1.1 below shows a man doing a demonstration on a machine in a workshop.



[Presented by RGD Rankine Pr.Eng, 2008]

**FIGURE 1.1**

- Explain FOUR safety rules concerning personal protection that the man did not adhere to when he worked with the machinery in the workshop. (4)
- 1.2 Distinguish between a *cornice* and a *skirting* with respect to:
- 1.2.1 Location (2)
- 1.2.2 Purpose (2)
- 1.3 You want to use timber poles to construct a timber carport.
- 1.3.1 Describe TWO reasons why you would use preserved timber poles. (2)
- 1.3.2 Name any type of preservative that can be used to preserve timber. (1)
- 1.4 Describe TWO reasons why stirrups are used in reinforcement. (2)
- 1.5 Predict TWO consequences of not installing DPC (damp-proof course) between the substructure and the superstructure at floor level in a building. (2)
- 1.6 Describe the first THREE steps that must be followed to prepare and paint a newly built concrete wall. (3)

1.7 FIGURE 1.7 below is a sketch of a steel profile.

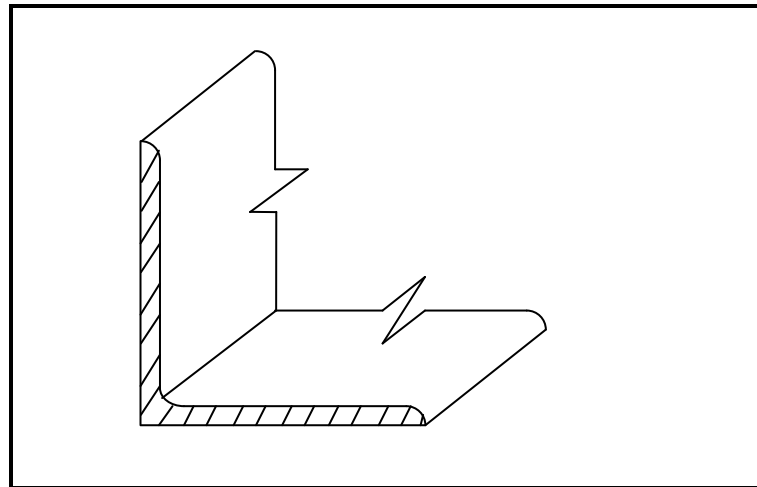

**FIGURE 1.7**

1.7.1 Identify the type of steel profile. (1)

1.7.2 Name ONE property of the steel profile. (1)

1.7.3 Where would you use this steel profile in a building? (1)

1.8 Name TWO parts of a ladder that you should inspect before using the ladder. (2)

1.9 FIGURE 1.9 below shows the front elevation of a window.

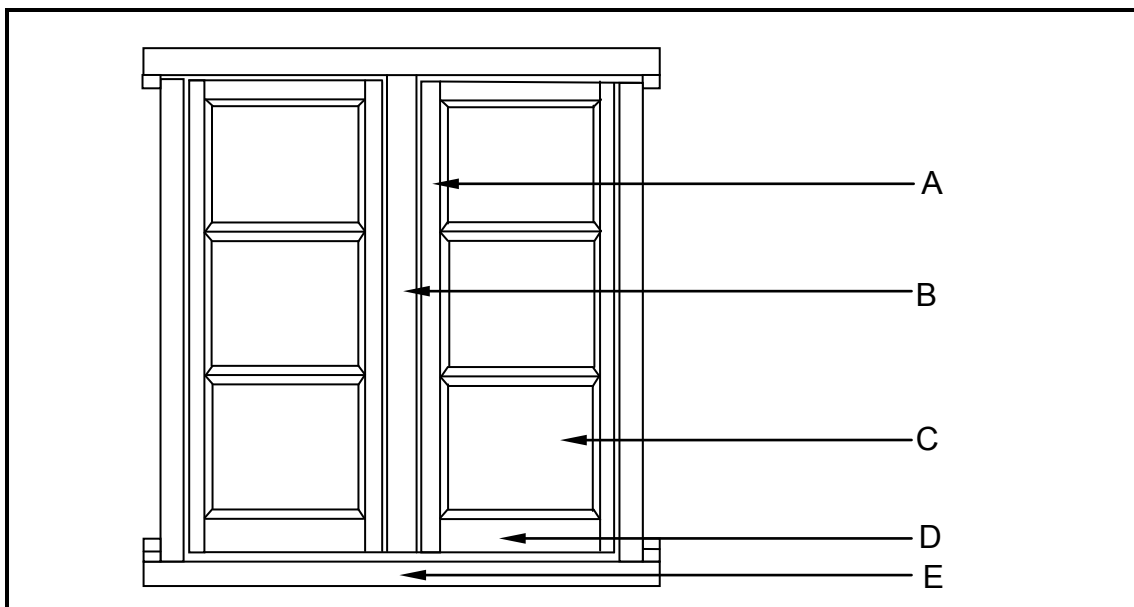

**FIGURE 1.9**

1.9.1 Identify the window. (1)

1.9.2 Label parts **A** to **E** in your ANSWER BOOK. (5)

1.10 Explain what is meant by *beam filling*. (1)

**[30]**

**QUESTION 2: ADVANCED CONSTRUCTION AND EQUIPMENT**

Start this question on a NEW page.

- 2.1 FIGURE 2.1 below is a drawing of a block used in the first floor of a double-storey house.

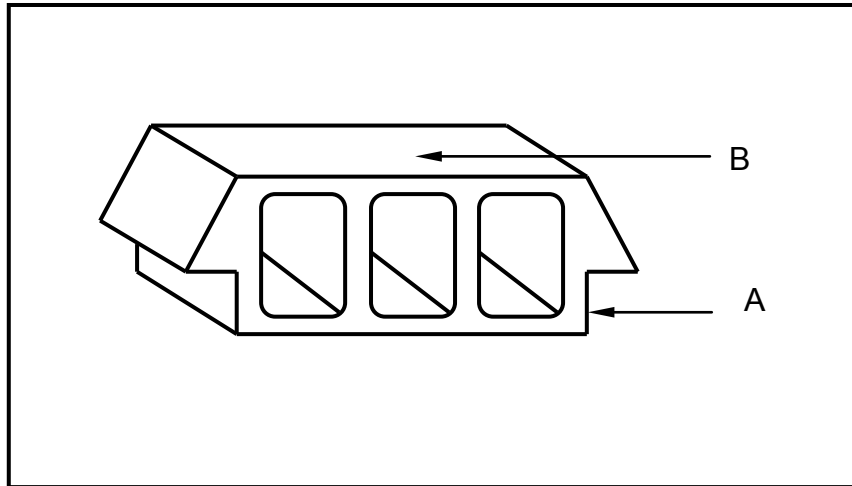

**FIGURE 2.1**

- 2.1.1 Describe the type of material that this block can be made of. (1)
- 2.1.2 Explain the purpose of the rebate at **A**. (1)
- 2.1.3 Name the type of reinforcement that will be used on top of the block at **B**. (1)
- 2.1.4 State ONE method that can be used to cure the newly cast concrete on top of **B**. (1)
- 2.1.5 Describe TWO functions of the holes in the block. (2)

- 2.2 FIGURE 2.2 below shows two readings on the middle stage lines at peg **A** and peg **B** as viewed through the eye piece of a dumpy level.

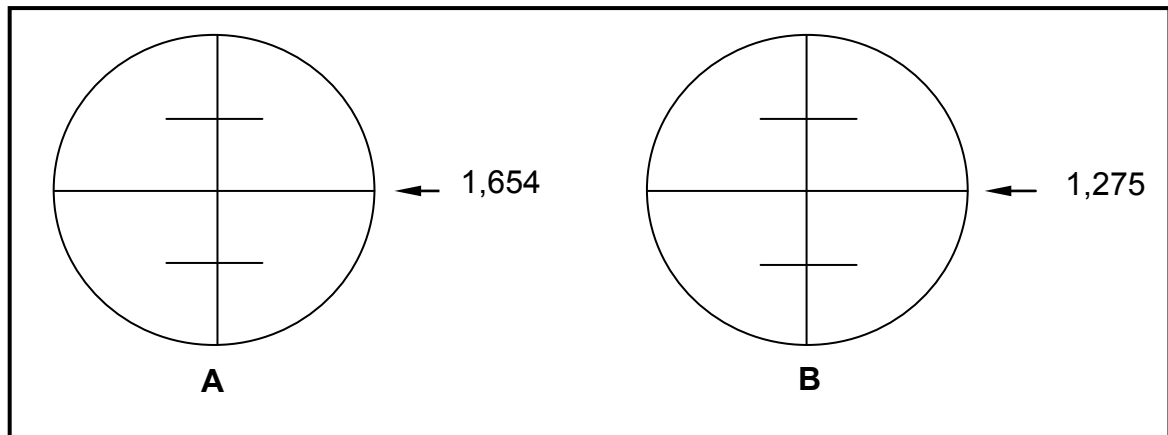

**FIGURE 2.2**

- 2.2.1 Calculate the difference in height between peg **A** and peg **B** as indicated in FIGURE 2.2. Show ALL the calculations in your ANSWER BOOK. (3)
- 2.2.2 State if there is a rise or a fall from **A** to **B**. (1)
- 2.3 State the purpose of the following equipment used in the installation of a roof:
- 2.3.1 Chalk line (1)
- 2.3.2 Building line (1)
- 2.4 Describe the care and maintenance of a tape measure. (2)

2.5 FIGURE 2.5 below shows a type of pile being installed.

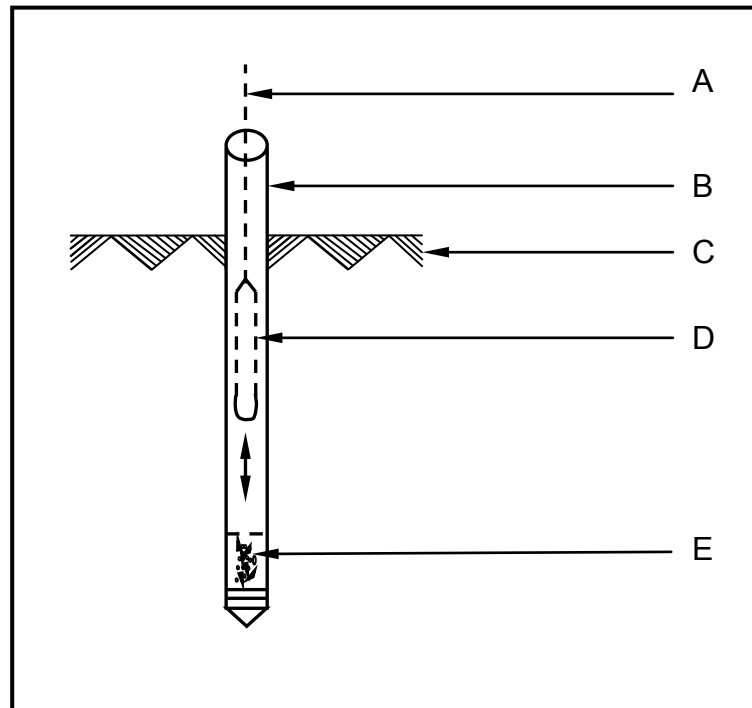

FIGURE 2.5

- 2.5.1 Label parts **A** to **E** in your ANSWER BOOK. (5)
- 2.5.2 Make a neat, freehand drawing of part **E** after the process has been completed. (2)
- 2.5.3 Explain the function of **D** in the process. (1)
- 2.5.4 Explain what happens to part **B** after the process has been completed. (1)
- 2.5.5 Explain under what conditions the type of pile in FIGURE 2.5 can be used. (1)
- 2.5.6 Name ONE other type of pile that can be used instead of the one in FIGURE 2.5. (1)
- 2.5.7 State ONE advantage of using part **B**. (1)
- 2.6 Explain TWO advantages of tiling a wall instead of painting the wall. (2)



- 2.7 Two round concrete columns are to be used as supports for billboards that are to be erected in front of your school. ANSWER SHEET 2.7 (attached) shows the lining and centre of one column.

Use ANSWER SHEET 2.7 and draw to scale 1 : 10 the complete horizontal section of the timber formwork for one column.

Show the following on your drawing:

- Laggings 38 mm x 38 mm
- Collars
- Bolts and nuts/Threaded rods with a diameter of 16 mm
- Vertical clamps/boards
- Symbol for concrete
- Print the title of the drawing

Use your own discretion for measurements not given.

(12)  
**[40]**

**QUESTION 3: CIVIL SERVICES**

Start this question on a NEW page.

- 3.1 People living in rural areas do not have access to a municipal water connection and obtain their water from rivers and streams.

Name ONE other natural source where they can get water. (1)

- 3.2 FIGURE 3.2 below show different pipe fittings to be used for the warm-water supply to a house.



**FIGURE 3.2**

3.2.1 Name the material used to make the fittings in FIGURE 3.2. (1)

3.2.2 Name the joint when these fittings are joined by soldering. (1)

3.3 Describe TWO advantages of an electric geyser. (2)

3.4 Explain the use of a drain cock on a geyser. (2)

3.5 Name TWO factors that influence the temperature of water heated by a solar geyser. (2)

3.6 Describe TWO factors to be considered when installing a solar geyser. (2)

3.7 Explain the following terms:

3.7.1 Sewage (1)

3.7.2 Soil water (1)

- 3.8 FIGURE 3.8 below shows the invert level of the sewer pipeline for a new house. The invert level of the pipeline at **B** is 1 385 mm and the pipe is 35 m long. The slope (fall) of the pipe is 1 : 40.

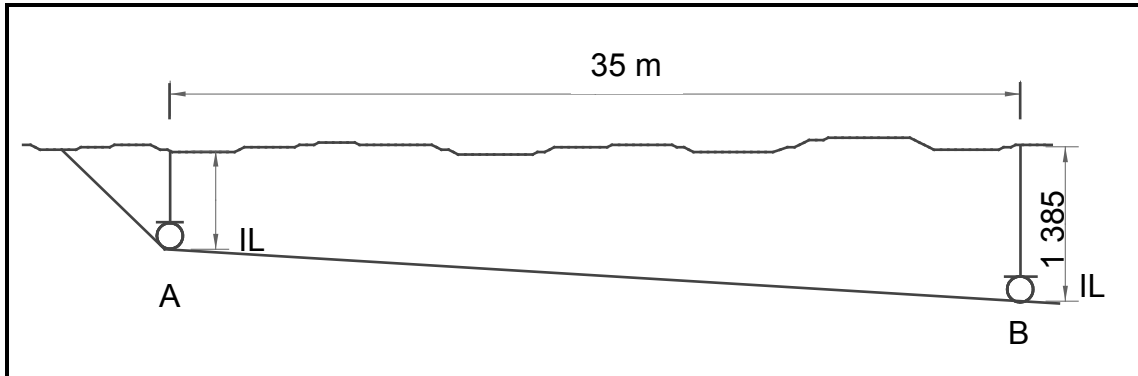
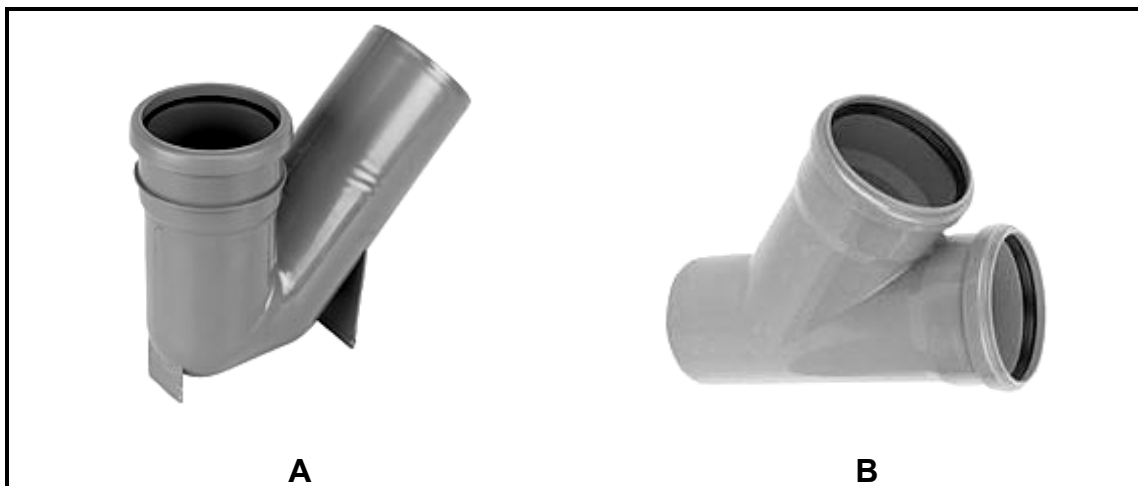

**FIGURE 3.8**

- 3.8.1 Calculate the slope in millimetres over the distance of 35 metres (between **A** and **B**). Show ALL the calculations in your ANSWER BOOK. (2)

- 3.8.2 Calculate the invert level at **A**. Show ALL the calculations in your ANSWER BOOK. (3)

- 3.9 FIGURE 3.9 below shows two drain fittings (**A** and **B**).



**FIGURE 3.9**

- Identify drain fittings **A** and **B** in FIGURE 3.9. (2)

3.10 Various options are provided as possible answers to the following questions. Choose the answer and write only the letter (A–D) next to the question (3.10.1–3.10.3) in the ANSWER BOOK, for example 3.10.4 B.

3.10.1 The function of a pressure reducing valve is to ...

- A heat water rapidly.
- B ensure that hot-water taps can be opened.
- C ensure that regular maintenance is done.
- D lower the high pressure of the water from the municipality. (1)

3.10.2 One way to maintain a solar heating system is to ...

- A clean the gas cylinders regularly.
- B paint the inside parts of the tray white.
- C keep the glass clean.
- D empty the primary return pipe after use. (1)

3.10.3 A gravity geyser ...

- A uses the sun to heat water.
- B is placed at an angle of 35° to the horizontal.
- C has a water storage tank above the geyser.
- D is fitted with a pressure reducing valve. (1)

3.11 Explain THREE advantages of using conduits in electrical installations. (3)

3.12 Make a freehand sketch of the symbol for the meter box. (2)

3.13 Storm water on a building site must be disposed of.

Name TWO methods that can be used to direct the storm water away from the site.

(2)  
**[30]**

**QUESTION 4: QUANTITIES, MATERIALS AND JOINING**

Start this question on a NEW page.

- 4.1 Name ONE place where you will use hoop iron in a building. (1)
- 4.2 Name the type of pipe that you will join when using the methods below:
- 4.2.1 Threaded pipe joints (1)
- 4.2.2 Plastic weld solvent (1)
- 4.3 Explain ONE use of each the following screws:
- 4.3.1 Coach screw (1)
- 4.3.2 Countersunk head screw (1)
- 4.4 Name TWO fasteners that can be used to join roof truss members. (2)
- 4.5 FIGURE 4.5 shows the floor plan of a storeroom with a door and a window.

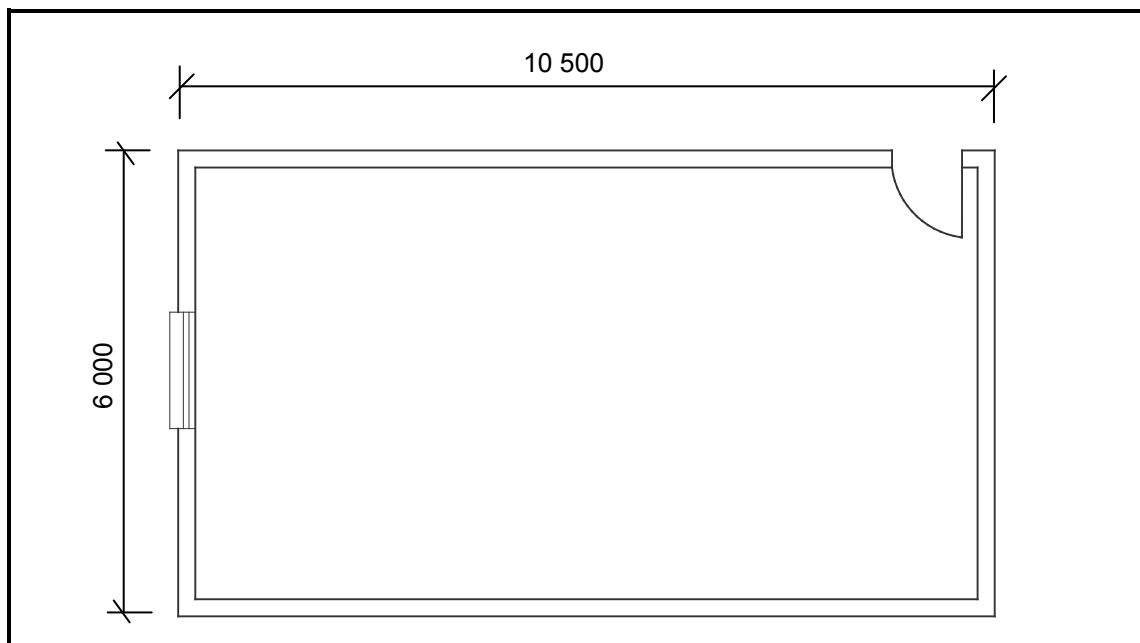
**FIGURE 4.5**

Specifications:

- The superstructure is a one-brick wall, 220 mm wide and 2 700 mm high.
- The door opening is 2 000 mm high x 800 mm wide.
- The window opening is 1 000 mm wide x 600 mm high.

Use ANSWER SHEET 4.5 and calculate the number of bricks needed to build the superstructure of the storeroom if 50 bricks are used to build 1 m<sup>2</sup> of a half-brick wall (110 mm wall). (19)

- 4.6 You want to compile a cutting list for the ceiling of a newly built bedroom. Name FOUR members/components/parts that will form part of the cutting list. (4)
- [30]**

**QUESTION 5: APPLIED MECHANICS**

Start this question on a NEW page.

- 5.1 FIGURE 5.1 below shows a shaped lamina with a triangular hole. All dimensions are in millimetres.

The area of the rectangle (Area 1) is  $2\,100\text{ mm}^2$ , the area of the square including the triangular hole (Area 2) is  $2\,500\text{ mm}^2$  and the area of the right-angled triangle (Area 3) is  $450\text{ mm}^2$ .

Calculate the position of the centroid of the lamina from **A–A**. Round off your answers to TWO decimal places.

**HINT:** Use the formula on the FORMULA SHEET.

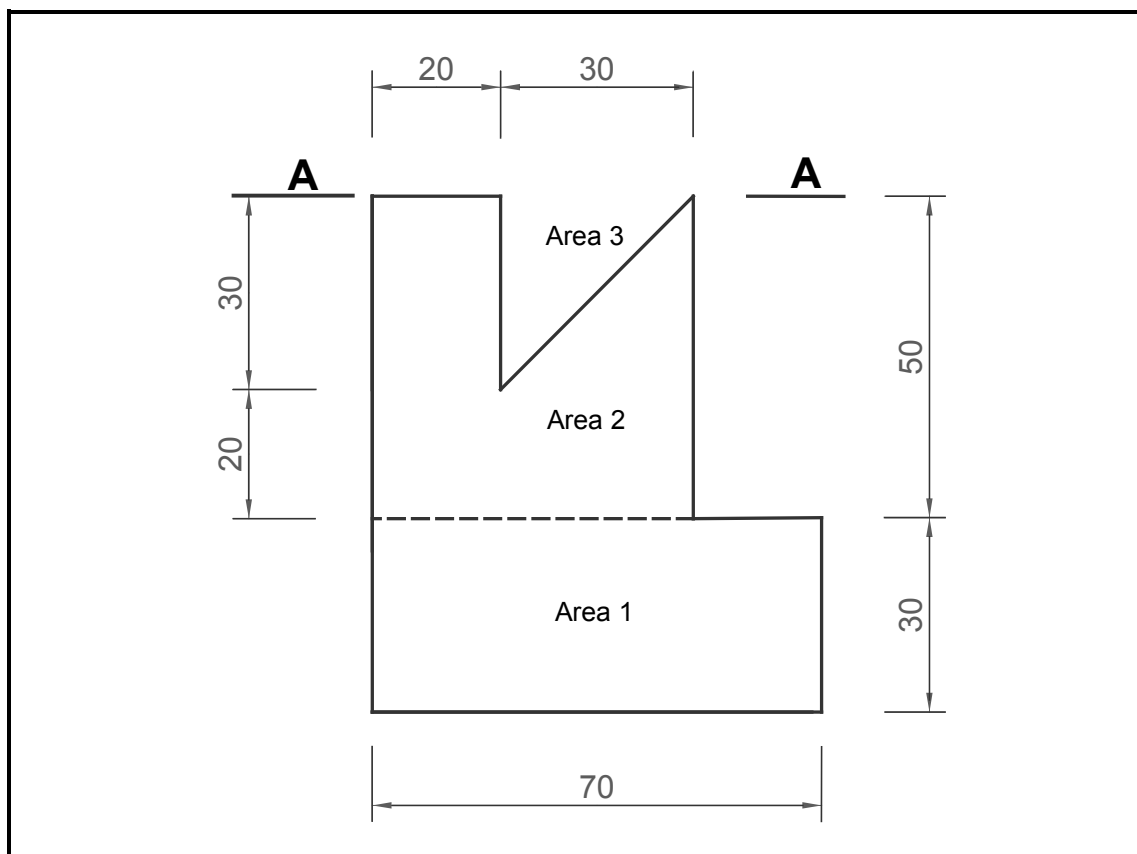

**FIGURE 5.1**

(8)

5.2 FIGURE 5.2 below shows the space diagram of a cantilever frame.

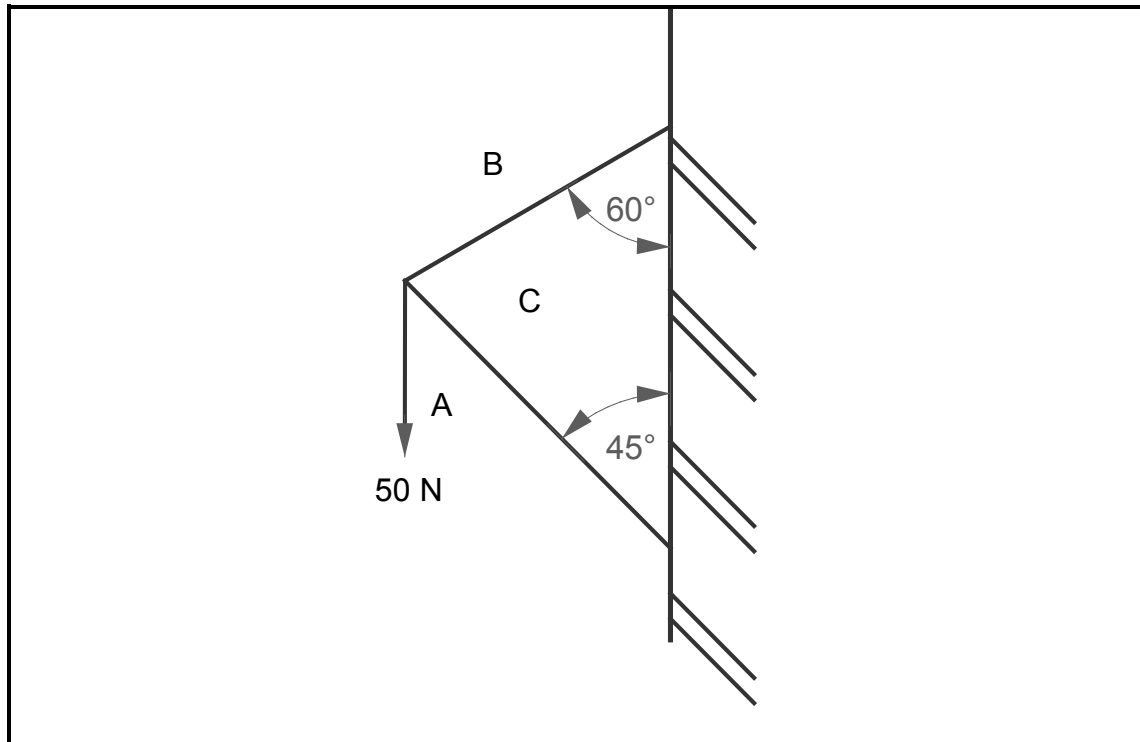

**FIGURE 5.2**

- 5.2.1 On ANSWER SHEET 5.2 develop and draw a vector diagram to graphically determine the magnitude and nature of the forces in each member (part) of the frame. Use scale 2 mm = 1 N. (6)
- 5.2.2 Show the nature of the forces of parts **BC** and **AC** on the space diagram on ANSWER SHEET 5.2. (2)
- 5.2.3 Use the information in the space and vector diagrams and complete the table on ANSWER SHEET 5.2. (4)

- 5.3 FIGURE 5.3 shows a beam of 8 metres resting on two supports. The beam carries a uniformly distributed load of 5 N/m and two point loads. Analyse the diagram and answer the questions that follow.

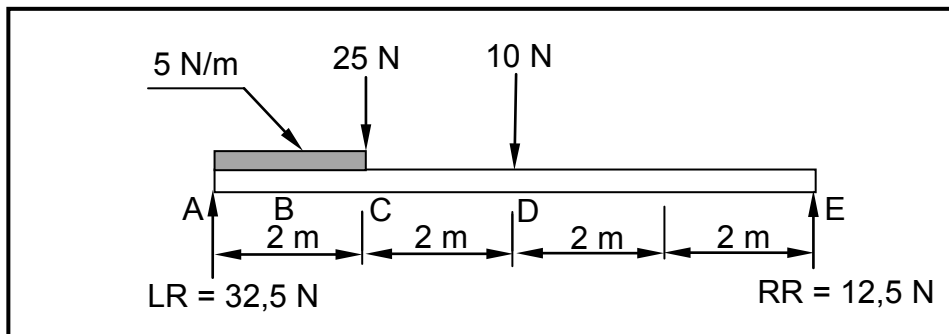

**FIGURE 5.3**

- 5.3.1 Convert the uniformly distributed load to a point load and write down the value of the converted point load. (1)
- 5.3.2 Determine the distance of the converted uniformly distributed load, which is now a point load, from **LR**. (1)
- 5.3.3 Prove, by means of calculations, that the value of the shear force at E = 0 N. (4)
- 5.3.4 Use the information below and draw the bending moment diagram to scale 1 mm = 1 Nm on ANSWER SHEET 5.3.

$$\begin{aligned} \text{BM}_a &= 0 \\ \text{BM}_b &= 30 \text{ Nm} \\ \text{BM}_c &= 55 \text{ Nm} \\ \text{BM}_d &= 50 \text{ Nm} \\ \text{BM}_e &= 0 \end{aligned}$$

(4)  
**[30]**



**QUESTION 6: GRAPHIC COMMUNICATION**

6.1 FIGURE 6.1 below illustrates the floor plan of a one-bedroom flat.

Study the drawing and complete the table on ANSWER SHEET 6.1.

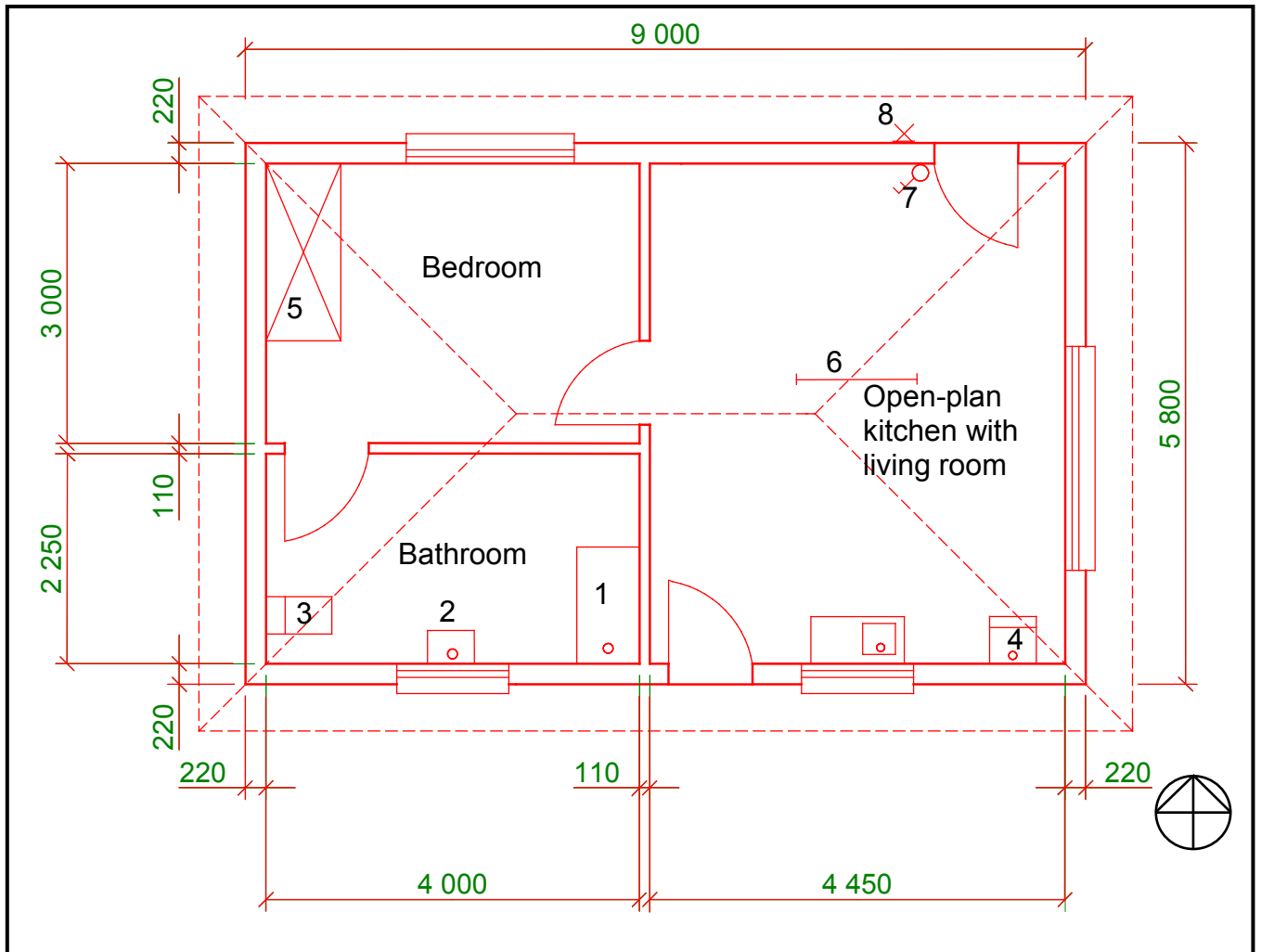

**FIGURE 6.1**

(15)

6.2 FIGURE 6.2 below shows the floor plan of a one-bedroom flat.

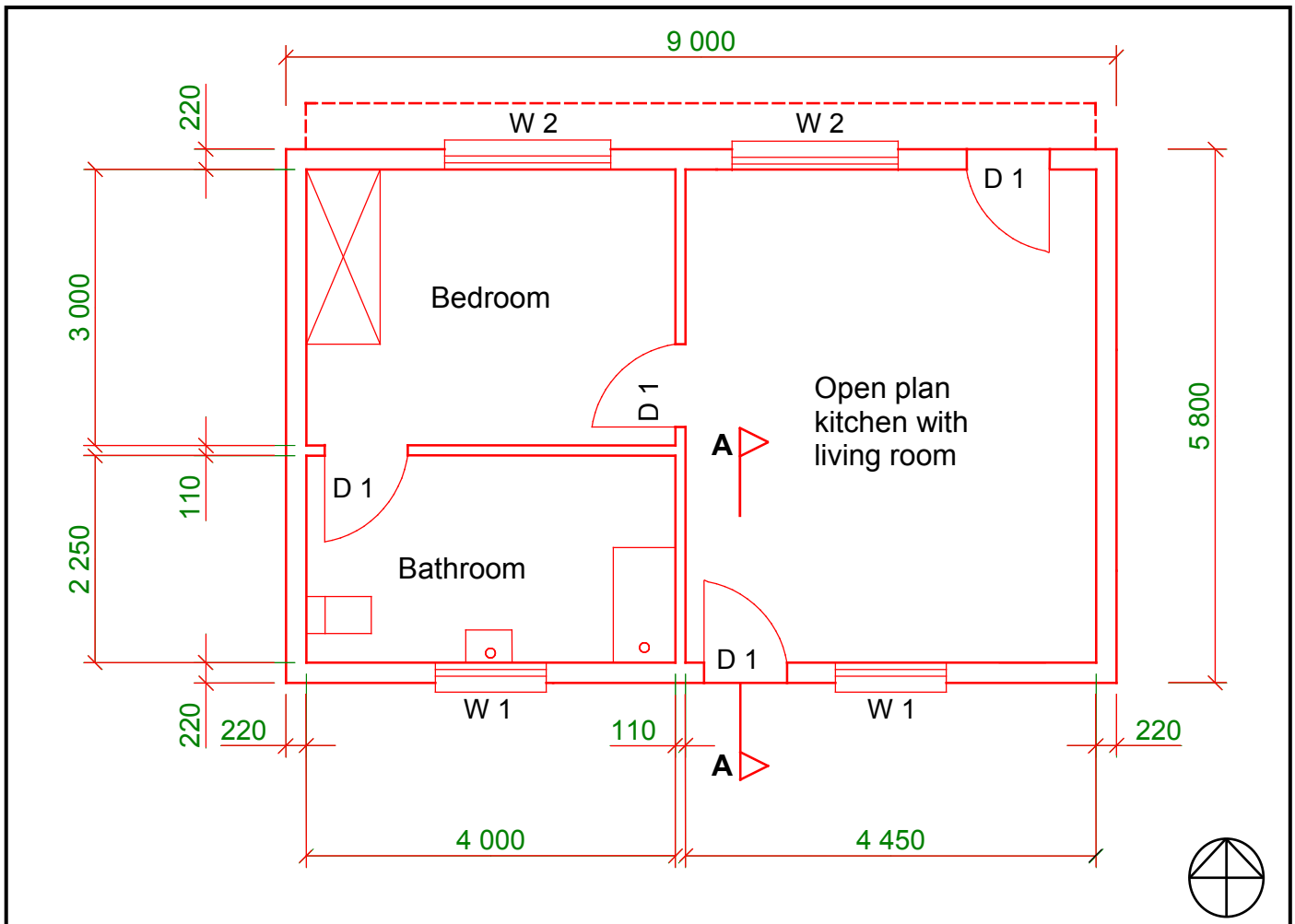

**FIGURE 6.2**

On ANSWER SHEET 6.2 draw to scale 1 : 20 a sectional view up to and including the wall plate of the building on section line **A–A**. Use the specifications below and on the next page.

6.2.1 Specifications:

- Foundation 600 mm wide and 250 mm deep
- All external walls are 220 mm wide
- Top of foundation to underside of floor slab, 450 mm
- Blinding layer, 50 mm thick
- Floor slab, 75 mm thick
- Screed, 25 mm thick
- Top of floor slab to underside of wall plate, 2 700 mm
- Wall plate, 114 mm x 38 mm
- Hard-core filling, 150 mm thick
- Height of door opening from floor screed, 2 050 mm
- The door frame is placed in the middle of the 220 mm wall and is 2 050 mm high and 110 mm wide.

The following must also be shown on the drawing:

- Earth fill
- Vertical dimensions of the foundation

The following must NOT be shown:

- Undisturbed earth
- Frame head of the door
- Rebate of the door frame (18)

- 6.2.2 Print the title below the drawing. (1)
- 6.2.3 Indicate any THREE labels. (3)
- 6.2.4 THREE marks will be allocated for the application of scale. (3)
- [40]**

**TOTAL: 200**



**CENTRE NUMBER:**

--	--	--	--	--	--	--	--	--	--

**EXAMINATION NUMBER**

--	--	--	--	--	--	--	--	--	--	--	--	--	--	--

**QUESTION 4.5**

**ANSWER SHEET 4.5**

Complete your answers in the spaces indicated with ... and ...

A	B	C	D
			Centre line: Superstructure
			2 / ... = ...
			2 / ... = ...
			Total = ...
			Minus 4 / ... = ...
			= ...
			Centre line: = ... (5)
1/	...		Area of wall for superstructure: (3)
	...	...	
1/	...		Area of door: (3)
	...	...	
1/	...		Area of window: (3)
	...	...	
			Total area of wall after deductions:
			= ... ..
			= (2)
2/	...		Bricks needed to build superstructure:
	...	...	... bricks are needed (3)
	<b>OR</b>		
1/	...		
	...	...	
			(19)

CENTRE NUMBER:

EXAMINATION NUMBER

**QUESTION 5.2**

**ANSWER SHEET 5.2**

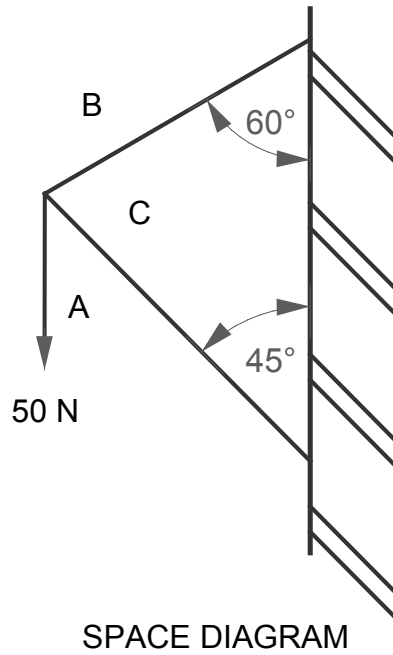

a

\_\_\_\_\_

MEMBER	NATURE	MAGNITUDE
BC		
CA		

Tolerance of 1 N to either side

<b>CENTRE NUMBER:</b>																				
-----------------------	--	--	--	--	--	--	--	--	--	--	--	--	--	--	--	--	--	--	--	--

<b>EXAMINATION NUMBER</b>																				
---------------------------	--	--	--	--	--	--	--	--	--	--	--	--	--	--	--	--	--	--	--	--

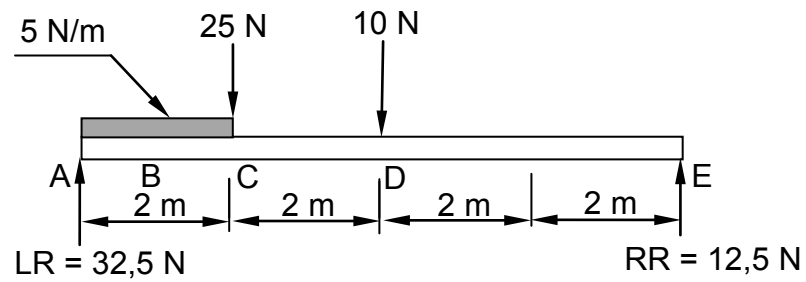
**QUESTION 5.3****ANSWER SHEET 5.3**

<b>CENTRE NUMBER:</b>									
-----------------------	--	--	--	--	--	--	--	--	--

<b>EXAMINATION NUMBER</b>														
---------------------------	--	--	--	--	--	--	--	--	--	--	--	--	--	--

**QUESTION 6.1****ANSWER SHEET 6.1**

<b>NO.</b>	<b>QUESTIONS</b>	<b>ANSWERS</b>	<b>MARKS</b>
1	Identify number 1.		1
2	Calculate the perimeter of the building.		1
3	Identify number 2.		1
4	Identify number 3.		1
5	Calculate the area of the floor of the bathroom in m <sup>2</sup> .		1
6	Identify number 4.		1
7	Identify number 5.		1
8	Name the type of roof of the building.		1
9	Identify the electrical symbol at 6.		1
10	Identify the electrical symbol at number 7.		1
11	Draw the symbol to indicate a sectional view of a face brick wall.		2
12	Identify number 8.		1
13	What elevation of the house must be drawn if you want to see the front of the bedroom?		1
14	How many doors are indicated on the drawing?		1
		<b>Total</b>	<b>15</b>



<b>CENTRE NUMBER:</b>									
-----------------------	--	--	--	--	--	--	--	--	--

<b>EXAMINATION NUMBER</b>															
---------------------------	--	--	--	--	--	--	--	--	--	--	--	--	--	--	--

**QUESTION 6.2****ANSWER SHEET 6.2**

<b>ASPECT</b>	<b>MARKS</b>	<b>LEARNER MARK</b>
Correctness of substructure	6	
Correctness of superstructure	7	
Correctness of any three drawing symbols	3	
Print any three labels	3	
Dimension and dimension lines	2	
Print of title	1	
Application of scale: One to two incorrect =3 Three or four incorrect =2 More than five incorrect =1 No measurement correct =0	3	
<b>Total</b>	<b>25</b>	

**FORMULA SHEET****IMPORTANT ABBREVIATIONS**

SYMBOL	DESCRIPTION	SYMBOL	DESCRIPTION	SYMBOL	DESCRIPTION
c	Centroid	b	Breadth/Width	h	Height
ℓ	Length	s	Side	A	Area

**FORMULAE**

AREA OF	FORMULA (in words)	FORMULA (in symbols)	FORMULA FOR THE POSITION OF CENTROIDS	
			X-axis	Y-axis
Square	side x side	s x s	$\frac{s}{2}$	$\frac{s}{2}$
Rectangle	length x breadth	ℓ x b	$\frac{\ell}{2}$	$\frac{b}{2}$
Right-angled triangle	$\frac{1}{2}$ x base x height	$\frac{1}{2}b \times h$	$\frac{b}{3}$	$\frac{h}{3}$
Equilateral triangle/ Pyramid/ Isosceles	$\frac{1}{2}$ x base x height	$\frac{1}{2}b \times h$	$\frac{b}{2}$	$\frac{h}{3}$

$$\text{Position of centroid} = \frac{(A1 \times d) \pm (A2 \times d)}{\text{Total area}}$$

**OR**

$$X = \frac{\sum Ax}{\sum A} \quad Y = \frac{\sum Ay}{\sum A}$$