

No part of this product may be reproduced in any form or by any electronic or mechanical means, including information storage and retrieval systems, without written permission from the IB.

Additionally, the license tied with this product prohibits commercial use of any selected files or extracts from this product. Use by third parties, including but not limited to publishers, private teachers, tutoring or study services, preparatory schools, vendors operating curriculum mapping services or teacher resource digital platforms and app developers, is not permitted and is subject to the IB's prior written consent via a license. More information on how to request a license can be obtained from <https://ibo.org/become-an-ib-school/ib-publishing/licensing/applying-for-a-license/>.

Aucune partie de ce produit ne peut être reproduite sous quelque forme ni par quelque moyen que ce soit, électronique ou mécanique, y compris des systèmes de stockage et de récupération d'informations, sans l'autorisation écrite de l'IB.

De plus, la licence associée à ce produit interdit toute utilisation commerciale de tout fichier ou extrait sélectionné dans ce produit. L'utilisation par des tiers, y compris, sans toutefois s'y limiter, des éditeurs, des professeurs particuliers, des services de tutorat ou d'aide aux études, des établissements de préparation à l'enseignement supérieur, des fournisseurs de services de planification des programmes d'études, des gestionnaires de plateformes pédagogiques en ligne, et des développeurs d'applications, n'est pas autorisée et est soumise au consentement écrit préalable de l'IB par l'intermédiaire d'une licence. Pour plus d'informations sur la procédure à suivre pour demander une licence, rendez-vous à l'adresse suivante : <https://ibo.org/become-an-ib-school/ib-publishing/licensing/applying-for-a-license/>.

No se podrá reproducir ninguna parte de este producto de ninguna forma ni por ningún medio electrónico o mecánico, incluidos los sistemas de almacenamiento y recuperación de información, sin que medie la autorización escrita del IB.

Además, la licencia vinculada a este producto prohíbe el uso con fines comerciales de todo archivo o fragmento seleccionado de este producto. El uso por parte de terceros —lo que incluye, a título enunciativo, editoriales, profesores particulares, servicios de apoyo académico o ayuda para el estudio, colegios preparatorios, desarrolladores de aplicaciones y entidades que presten servicios de planificación curricular u ofrezcan recursos para docentes mediante plataformas digitales— no está permitido y estará sujeto al otorgamiento previo de una licencia escrita por parte del IB. En este enlace encontrará más información sobre cómo solicitar una licencia: <https://ibo.org/become-an-ib-school/ib-publishing/licensing/applying-for-a-license/>.

**Design technology**  
**Higher level**  
**Paper 1**

Thursday 5 November 2020 (afternoon)

1 hour

---

**Instructions to candidates**

- Do not open this examination paper until instructed to do so.
- Answer all the questions.
- For each question, choose the answer you consider to be the best and indicate your choice on the answer sheet provided.
- The maximum mark for this examination paper is **[40 marks]**.

1. Which part of the human information processing system would most likely be affected by mental stress?
  - A. Motor processes
  - B. Output
  - C. Sensory processes
  - D. Central processes
  
2. Which of the following is a biomechanical consideration?
  - A. Torque
  - B. Alertness
  - C. Static data
  - D. Adjustability

3. **Figure 1** is an example of a tool used by designers.

**Figure 1: A tool used to demonstrate the stages and impacts of a project**

		Environmental considerations								
		Water			Air		Soil		Biological	
		Surface	Subsurface	Coastal	Quality	Noise	Quality	Erosion	Flora	Fauna
Project stages	Production	4		4	3	3				
	Logistics				4	4				
	Fitting					3	3	2	4	4
	Operation				4	4				

What is **Figure 1** an example of?

- A. Life cycle analysis (LCA) matrix
- B. Design for the environment software
- C. Affinity diagramming
- D. Environmental impact assessment matrix

4. Which of the following renewable energy resources could be considered as having the least environmental and social impact?
  - A. Geothermal energy
  - B. Solar
  - C. Wind
  - D. Hydropower
  
5. Which of the following best describes a circular economy?
  - A. Maximizing the amount of material that can be recycled
  - B. Designing products so they produce the minimal amount of pollution
  - C. Designing products so their waste can be used as a resource
  - D. Designing products so they can be disposed of as easily as possible
  
6. Which of the following statements are true of life cycle analysis (LCA)?
  - I. Straight forward
  - II. Expensive
  - III. Time consuming
  - A. I and II only
  - B. I and III only
  - C. II and III only
  - D. I, II and III
  
7. Focussing on one or two environmental objectives is considered a strategy for...
  - A. Eco-design
  - B. Radical design
  - C. Green design
  - D. Constructive discontent

- 8. What might be considered a disadvantage of an incremental solution?
  - A. It requires considerable expenditure on research and development
  - B. It causes minimal disruption
  - C. It requires a high capital investment
  - D. It focuses on short-term goals
  
- 9. **Figure 2** shows a freehand drawing and an orthographic projection of a chair.

**Figure 2: Different representations of a chair**

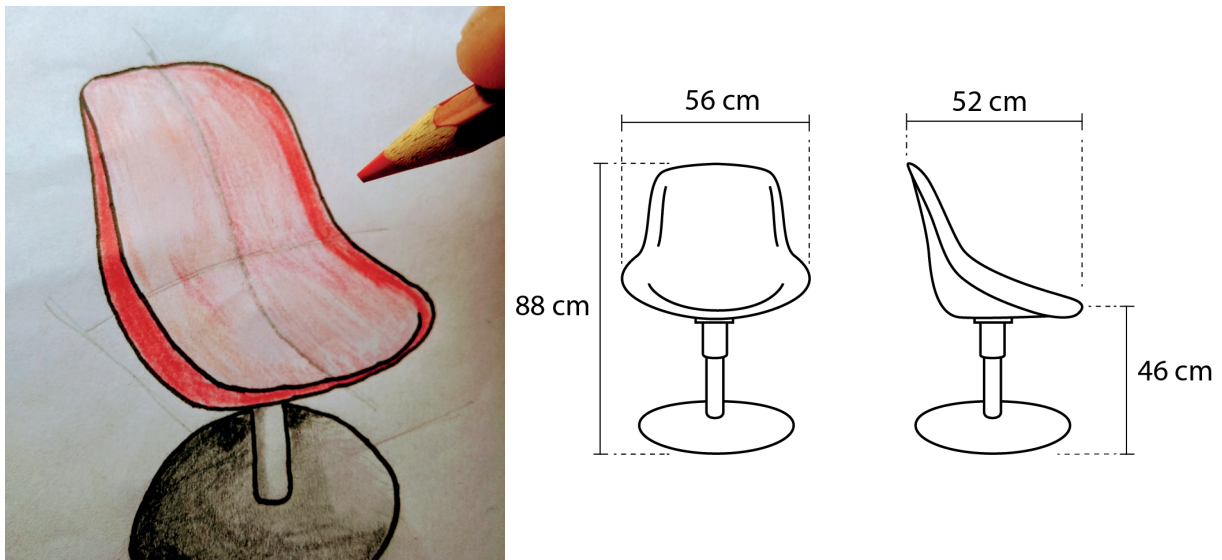

- What is an advantage of using a freehand drawing rather than an orthographic drawing?
- A. More accurate
  - B. Allows quick exploration of ideas
  - C. Can be given to a manufacturer to make it
  - D. All parts drawn in proportion
- 
- 10. What rapid prototyping process uses lasers to solidify layers from a liquid resin?
    - A. Stereolithography (SLA)
    - B. Fused deposition modelling (FDM)
    - C. Selective laser sintering (SLS)
    - D. Laminated object manufacturing (LOM)

11. Figure 3 shows an industrial robotic arm.

Figure 3: An industrial robotic arm

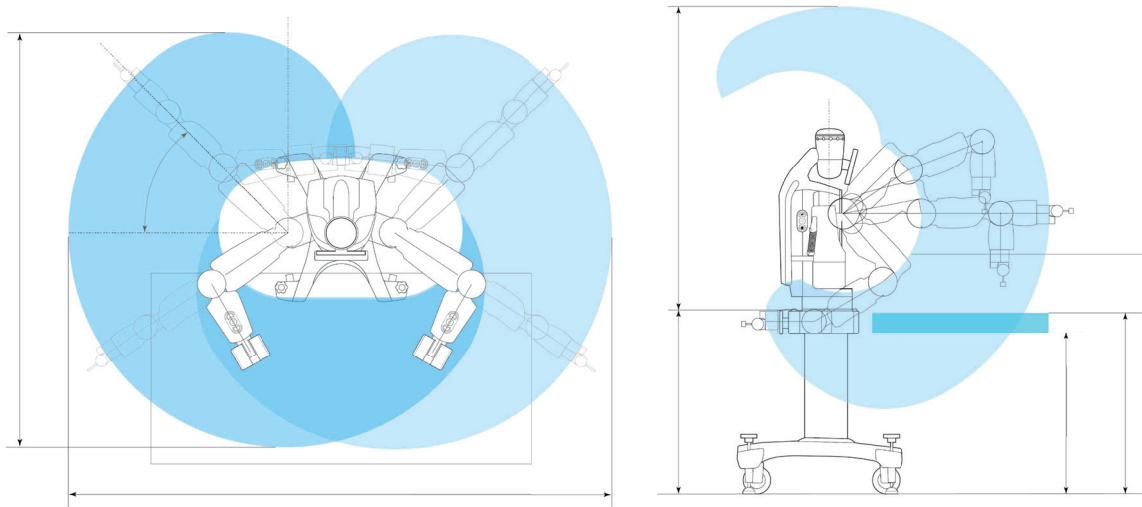

The blue shaded area shows how far the robotic arm can reach. What is this area called?

- A. Task area
  - B. Work envelope
  - C. Load capacity
  - D. Load area
12. Which of the following would affect the choice of a production system?
- I. Labour
  - II. Skills and training
  - III. Impact on the environment
- A. I and II only
  - B. I and III only
  - C. II and III only
  - D. I, II and III

13. Which of the following is a permanent joining method?
- A. Nuts and bolts
  - B. Screws
  - C. Fusing
  - D. Velcro
14. Which of the following are required to extract iron from its ore?
- I. Coke and limestone
  - II. A blast furnace
  - III. Electrolysis
- A. I and II only
  - B. I and III only
  - C. II and III only
  - D. I, II and III
15. What property does a material have if it can be drawn or extruded into wires and does not break or return to its original shape?
- A. Tensile strength
  - B. Ductility
  - C. Elasticity
  - D. Toughness
16. Timber is often dried in large ovens called kilns. What is the reason for this?
- A. To improve aesthetics
  - B. To protect it from insects
  - C. To soften the wood for easier manufacture into products
  - D. To prevent the wood deforming



17. Nike is a global running shoe brand well recognized by the Nike Swoosh (tick) design.

Figure 4 removed for copyright reasons

Which of the following intellectual property (IP) strategies would be used to prevent any other company from copying the Nike Swoosh design?

- A. Copyright ©
  - B. Patent
  - C. Trademark ®
  - D. Service mark (SM)
18. At which stage of the product life cycle might a company consider releasing a new generation of the product?
- A. Launch
  - B. Growth
  - C. Maturity
  - D. Withdrawal

19. Which type of obsolescence best describes a product that has been replaced due to changes of consumer tastes?
- A. Planned
  - B. Style (fashion)
  - C. Technological
  - D. Function
20. Which of the following statements are true of classic designs?
- I. The function of the product is better than its competitors
  - II. The form of the product provokes emotional reactions
  - III. Obsolescence does not impact the product's popularity
- A. I and II only
  - B. I and III only
  - C. II and III only
  - D. I, II and III

21. Figure 5 shows four different products.

Figure 5: Four different products



Identify the product where the psychological function rather than practical function was the determining factor in the design.

- A. Lockheed lounge chair
- B. Oxo Grip vegetable peeler
- C. Sports glasses for children
- D. Exoskeleton

22. **Figure 6** shows a USB cable which can only fit into a computer in one way.

**Figure 6: A USB cable**



Which characteristic of a good user interface does this demonstrate?

- A. Intuitive logic and organization
  - B. Constraints
  - C. Mapping
  - D. Affordance
23. A common strategy for user-centred design (UCD) involves selecting users to represent the 2.5th and the 97.5th percentile of the population. Products are then tested to ensure that they function efficiently for those users. What does this strategy describe?
- A. Method of extremes
  - B. Affinity diagramming
  - C. Participatory design
  - D. Field research

24. **Figure 7** shows an infographic a company has created to show the efforts they are making to ensure their product is more sustainable.

**Figure 7: A sustainability infographic**

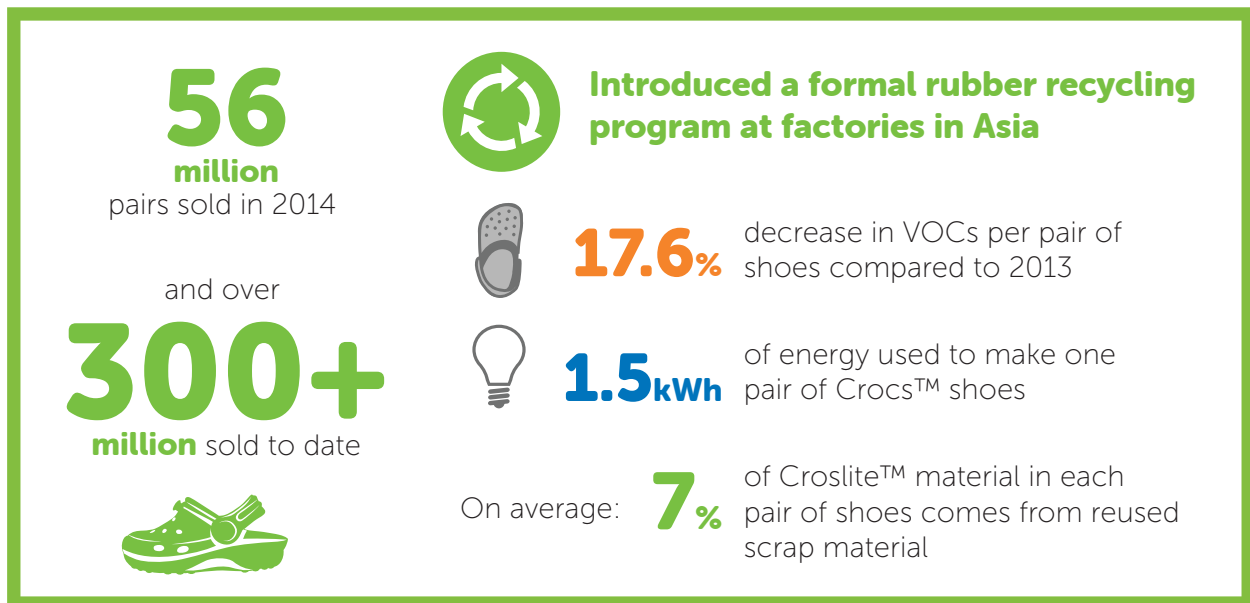

What is this infographic an example of?

- A. Triple bottom line sustainability
  - B. Decoupling
  - C. Sustainability reporting
  - D. Product stewardship
25. Greenpeace is an organization that regularly arranges demonstrations opposing practices that they believe will damage the environment. Greenpeace is an example of...
- A. An eco phobe
  - B. A pressure group
  - C. A lifestyle consumer
  - D. An eco fan

26. Which of the following are true of a green design?
- I. Meets all parts of the triple bottom line
  - II. Is a short-term solution
  - III. Has a cradle to grave approach
- A. I and II only
  - B. I and III only
  - C. II and III only
  - D. I, II and III
27. Some sustainable energy innovations are initiated by individuals and businesses through local initiatives. Which term best describes this?
- A. Regulation
  - B. Macro energy sustainability
  - C. Energy security
  - D. Micro energy sustainability

28. **Figure 8** shows a range of sunscreen products from different manufacturers.

**Figure 8: A range of sunscreen products**



G&C were the first to launch their sunscreen onto the market in 2015 priced at US\$2.99. Solis and Living Suncare launched their products in 2016 at the same price as G&C.

Which strategy of price setting best describes the one used by Solis and Living Suncare?

- A. Competitor-based pricing
- B. Psychological pricing
- C. Product line pricing
- D. Demand pricing

29. The iameco D4R laptop is marketed as “the first truly environmentally-friendly laptop”. Iameco focussed on what the laptop is made from and how it is made in order to reduce energy consumption, encourage re-use and eliminate waste.

The goals in developing the laptop were:

- to achieve a decrease of at least 30% in greenhouse gas (GHG) emissions
- to re-use and recycle at least 70% of the waste
- to ensure a reduction of at least 75% of fresh water utilization.

Iameco used market segmentation to identify target markets for their laptop.

Which of the following characteristics was most likely to be considered in the design and manufacture of the Iameco laptop?

- A. Profession
  - B. Income
  - C. Age
  - D. Values
30. Which of the following best describes diversification?
- A. Existing products, New markets
  - B. Existing products, Existing Markets
  - C. New products, New markets
  - D. New products, Existing markets
31. Which of the following best describes the market research strategy of gathering information about the external world, competitors and the organization itself to identify external opportunities and threats?
- A. Market surveys
  - B. Perceptual mapping
  - C. Environmental scanning
  - D. User research



32. **Figure 9** shows a graph measuring how parts of a manufacturing process are within tolerance. These are recorded so that if a process is erratic within the upper or lower control limit, the manufacturing process can be changed to improve it.

**Figure 9: A graph showing process output**

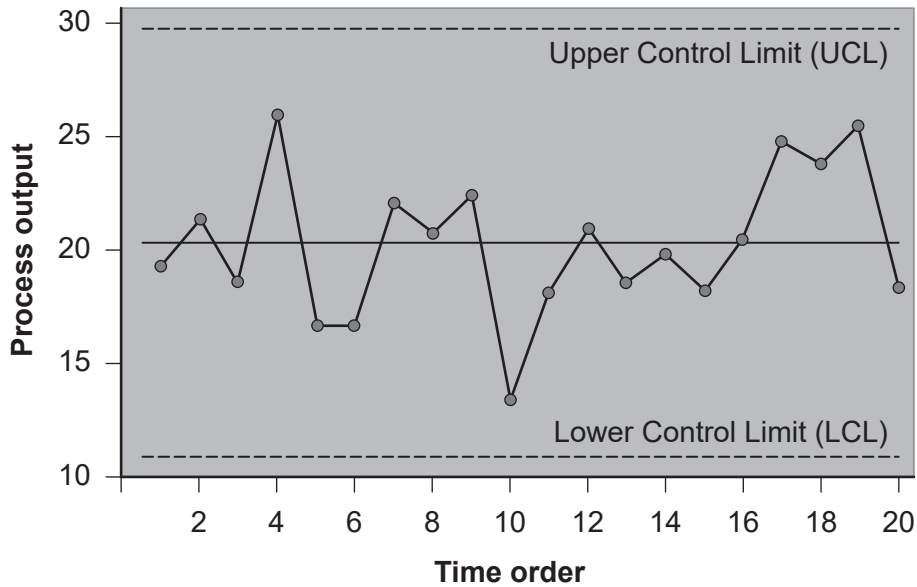

What quality management technique does this process describe?

- A. Kaizen
  - B. Statistical process control
  - C. Quality assurance
  - D. Value stream mapping
33. A manufacturer can sell their products in bulk to a retailer for a reduced price. What is the name of this pricing strategy?
- A. Unit cost
  - B. Retail price
  - C. Wholesale price
  - D. Typical manufacturing price

- 34.** Which of the following are monitored in computer integrated manufacturing (CIM)?
- I. Purchasing
  - II. Recovery of products at the end of their useful life
  - III. Distribution
- A. I and II only
  - B. I and III only
  - C. II and III only
  - D. I, II and III
- 35.** A manufacturer can review the sequence of production, tools used and worker movement to help identify areas of improvement. What is the name of this lean production concept, often shown as a flow chart?
- A. Value stream mapping
  - B. Lead time
  - C. Sorting
  - D. Workflow analysis

Questions 36 – 40 relate to the following case study. Please read the case study carefully and answer the questions.

**Figure 10** and **Figure 11** show the Werner ProForm™ F3 Construction Harness. In the event of a fall, a construction worker can pull a cord to release a built-in seat to reduce the likelihood of injury.

The product was developed by Priority Designs after workers were careless when putting on traditional harnesses. After a fall, workers would often be suspended for hours, awaiting rescue in an extremely uncomfortable and potentially dangerous situation with their harness often being the cause of extreme pain.

This harness is manufactured using lightweight materials to deliver maximum comfort and safety performance. The parts of the harness that connect with the body promote airflow and maximize comfort.

**Figure 10: Quick Connect buckle system**



**Figure 11: Adjustable straps are used to maximize comfort**



36. Which of the following is the most likely driver for invention for the Werner ProForm™ F3 Construction Harness?
- A. Desire to make money
  - B. Constructive discontent
  - C. Scientific curiosity
  - D. Technological breakthrough
37. Which of the following material properties would be most important for the part of this harness that connects the worker to the built-in seat?
- A. Ductility
  - B. Compressive strength
  - C. Stiffness
  - D. Tensile strength
38. The comfort of the workers using this harness is what type of human factor?
- A. Psychological
  - B. Physiological
  - C. Anthropometrics
  - D. Adjustability
39. The buckle closing system of this harness was virtually prototyped to identify areas of high stress on the material. What computer aided design (CAD) method would be used for this?
- A. Instrumented models
  - B. Surface modelling
  - C. Finite element analysis (FEA)
  - D. Virtual reality

40. The materials for the harness were only sourced from companies that comply to ISO standard 9001. Which quality management principle is this an example of?
- A. Quality control (QC)
  - B. Quality assurance (QA)
  - C. Statistical process control (SPC)
  - D. Workflow analysis
-

## References:

- Figure 1** © International Baccalaureate Organization 2020.
- Figure 2** [freehand drawing of a chair] © International Baccalaureate Organization 2020.  
[orthographic drawing of a chair] © International Baccalaureate Organization 2020.
- Figure 3** Image with permission from Hunan Cothinkrobotics Technology Co. Ltd.
- Figure 5** [Lockheed lounge chair] Courtesy of Phillips, photograph by Clint Bowers, and Marc Newson Limited for providing the image.  
[OXO Grip vegetable peeler] OXO Y Peeler.  
[exoskeleton] [https://commons.wikimedia.org/wiki/File:Honda\\_Walking\\_Assist\\_Device\\_with\\_Bodyweight\\_Support\\_System\\_front\\_2013\\_Tokyo\\_Motor\\_Show.jpg](https://commons.wikimedia.org/wiki/File:Honda_Walking_Assist_Device_with_Bodyweight_Support_System_front_2013_Tokyo_Motor_Show.jpg). Image by Morio under copyright CC 3.0 licence (<https://creativecommons.org/licenses/by-sa/3.0/deed.en>).
- Figure 7** Crocs, 2014. *2014 Sustainability Report*. <https://www.crocs.co.uk/pg/sustainability-report.html>.  
With permission from Crocs, Inc.
- Figure 8** [3 sunscreen products] © International Baccalaureate Organization 2020.
- Figure 9** Copyright OPEX Resources Ltd 2020. Reproduced with permission from [opexresources.com](http://opexresources.com) and the publication 'Lean Six Sigma and Minitab'. ISBN: 978 0995789944.
- Figure 10** [Werner ProForm F3 Construction Harness Quick Connect buckle system] Courtesy of Werner.
- Figure 11** [Werner ProForm F3 Construction Harness] Courtesy of Werner.