

UNIVERSITY OF CAMBRIDGE INTERNATIONAL EXAMINATIONS
International General Certificate of Secondary Education

DESIGN AND TECHNOLOGY
DESIGN AND COMMUNICATION

0445/02
0446/02

Paper 2 Graphic Products

Specimen Paper 2007

Candidates answer on the two inserted question sheets.

1 hour

Additional Materials: Standard drawing equipment

To be taken together with Paper 1 in one session of 2 hours 15 minutes.

READ THESE INSTRUCTIONS FIRST

Write your Centre Number, Candidate Number and Name in the spaces on **both** printed question sheets.
Draw your answers in the spaces provided on the question sheets.
Do not use staples, paper clips, highlighters, glue or correction fluid.

Section A

Answer **all** questions in this section (A1, A2 and A3).

Section B

Answer **one** question in this section (B4 or B5).

All construction and projection lines must be clearly shown.

All dimensions are in millimetres.

The total of the marks for this paper is 50.

At the end of the examination, tie the two question sheets together.

The number of marks is given in brackets [] at the end of each question or part question.

You may use a calculator.

This document consists of **1** A4 page and **4** A3 pages.



Section A

Answer **all** questions in this section.

A1 A child's shape sorter box is shown below with **one** of the six shape holes drawn in position.

The full-size plan view of the shape sorter box, with one shape completed, is drawn to the right.

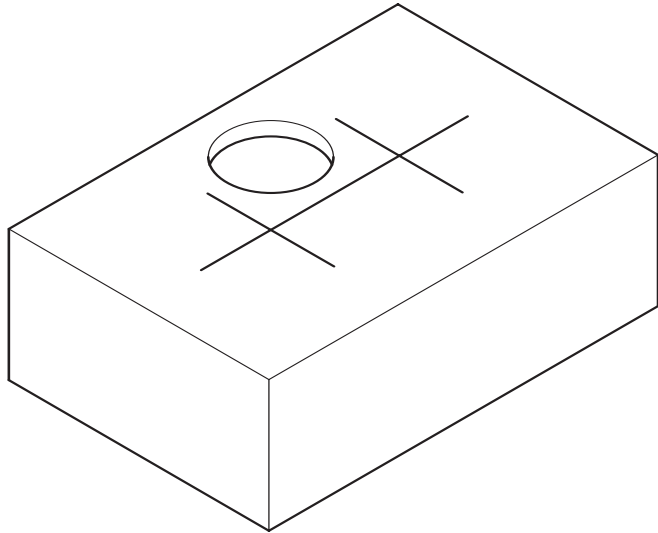

Complete the full-size plan view of the shape sorter box by drawing in the spaces provided:

- a regular **hexagon** side 30;
- a **diamond** 50 x 60 diagonals;
- a **rectangle** hole 50 x 40;
- a **semi-circle** Ø60;
- an equilateral **triangle** side 50.

[9]

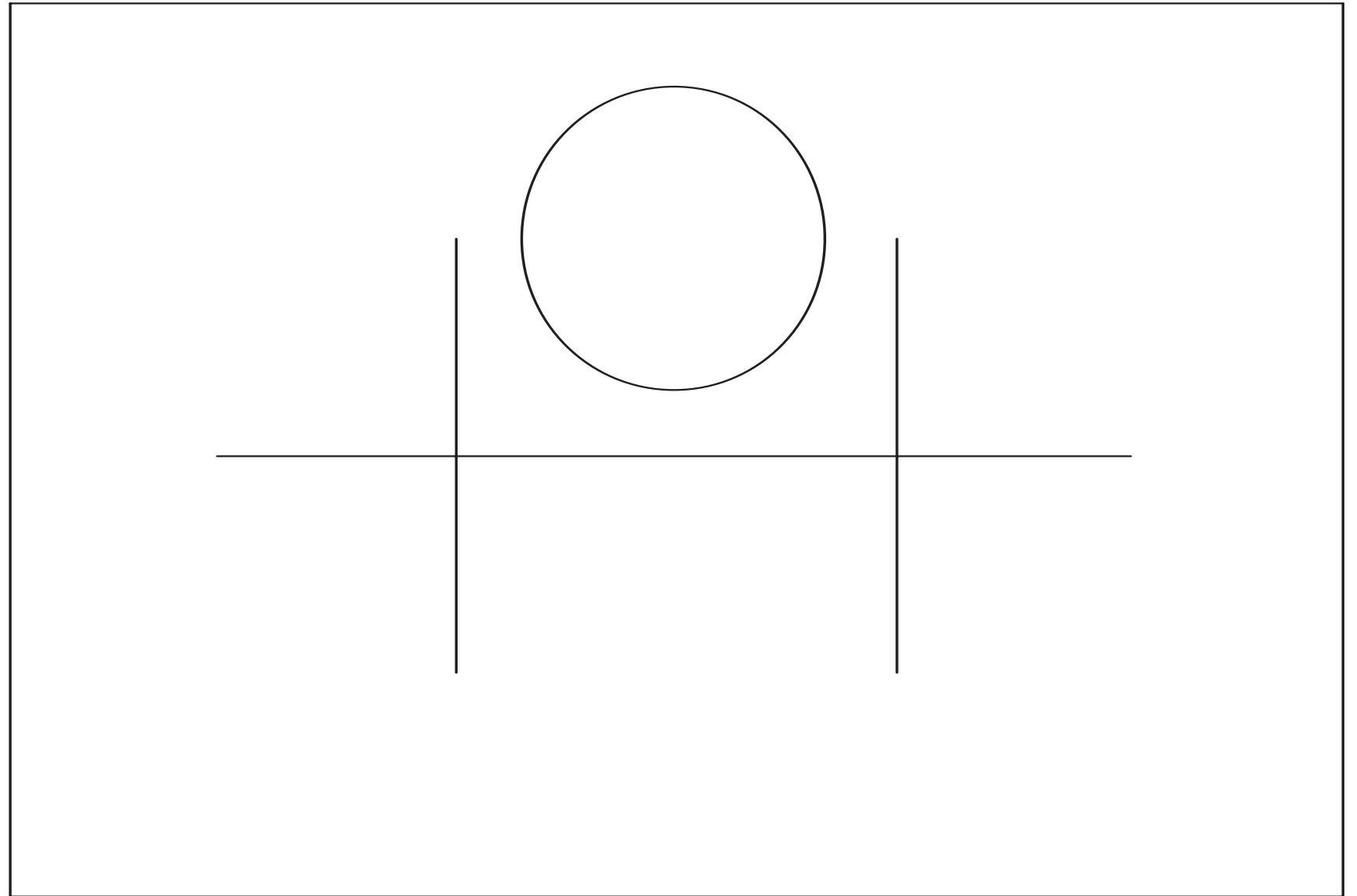

Plan View of shape sorter box

A2 An incomplete road sign for PARKING is drawn to the right.

Complete the road sign by adding the **four** remaining letters. All the letters must be the same height and style as those given. [6]



For
Examiner's
use

0445/02
0446/02 Specimen Paper 2007 **1 hour**
© UCLES 2005 SJF3907/CG T01801/2

Centre Number

Candidate's Number

Candidate's Name

support post

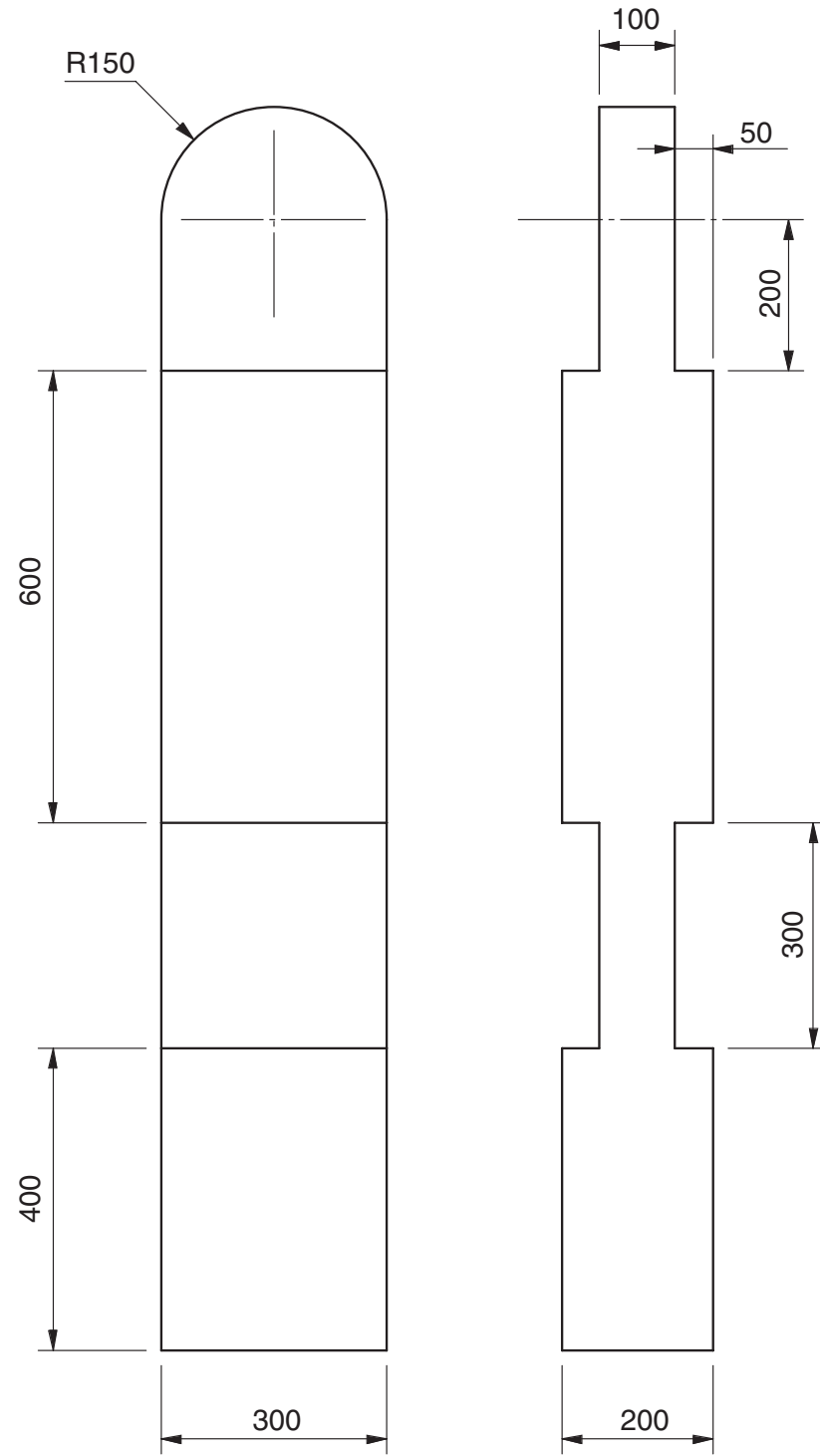

scale 1:10

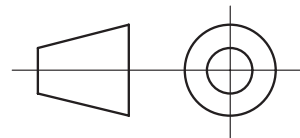

A3 A support post for a temporary barrier is drawn to a scale of 1:10 in the orthographic views given to the left.

In the space given to the right:

- (a) Sketch freehand, an isometric view of the support post. The sketch should be to the same scale and all sizes should be taken from the given orthographic views. [6]
- (b) Apply the thick and thin line technique to enhance your isometric sketch. [4]

Isometric sketch

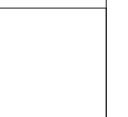

Section B

Answer **either** question **B4** or question **B5**.

B4 A National car museum uses an illustration of an old car as its logo, as shown in the sketch below.

Complete the full-size drawing of the logo by:

- (a) drawing the other wheel; [5]
- (b) drawing the semi-octagon; [5]
- (c) constructing the semi-ellipse; [5]
- (d) constructing the two R55 inner arcs; [5]
- (e) drawing the headlamp in position on the logo by enlarging the given drawing. [5]

headlamp

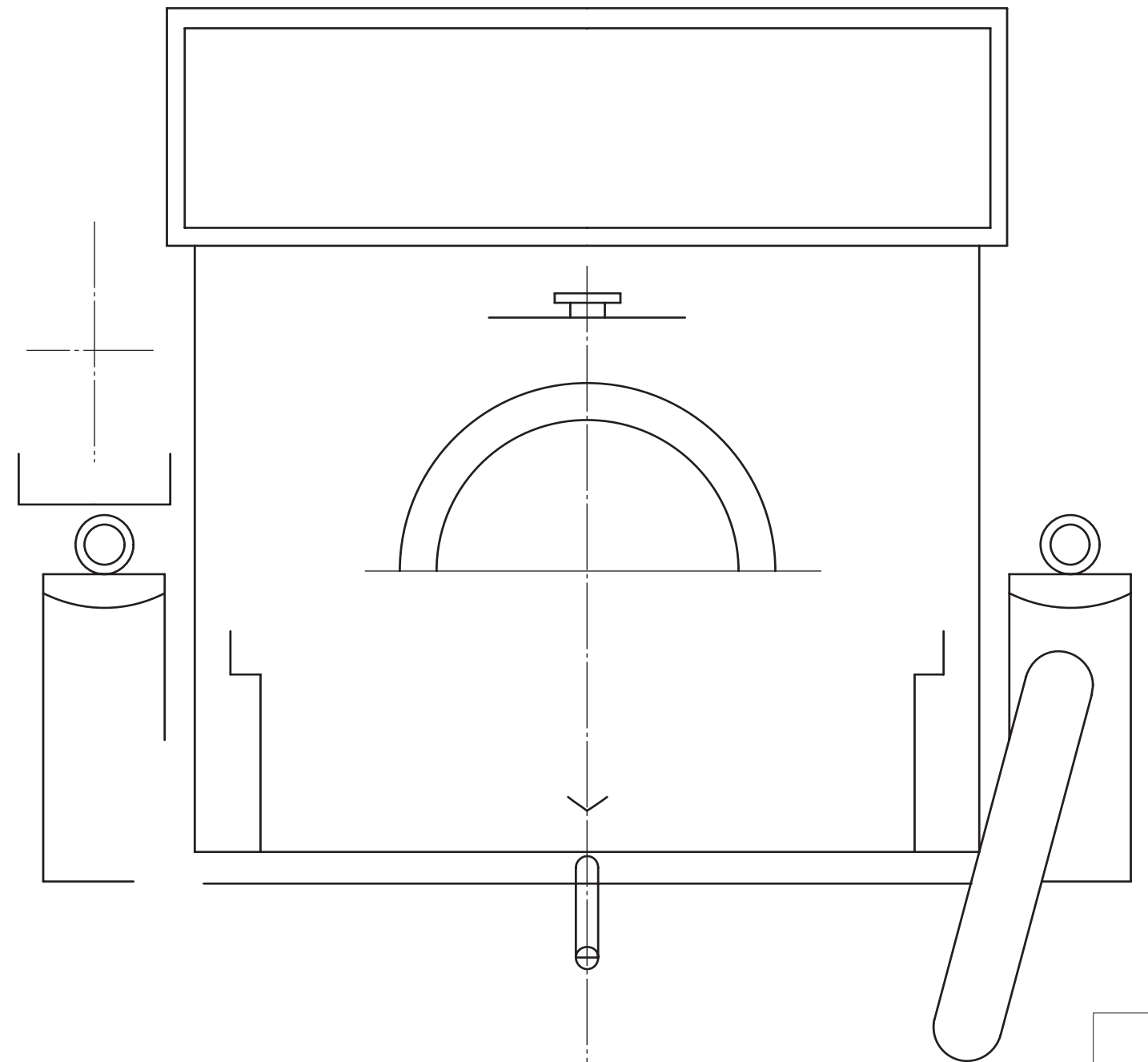
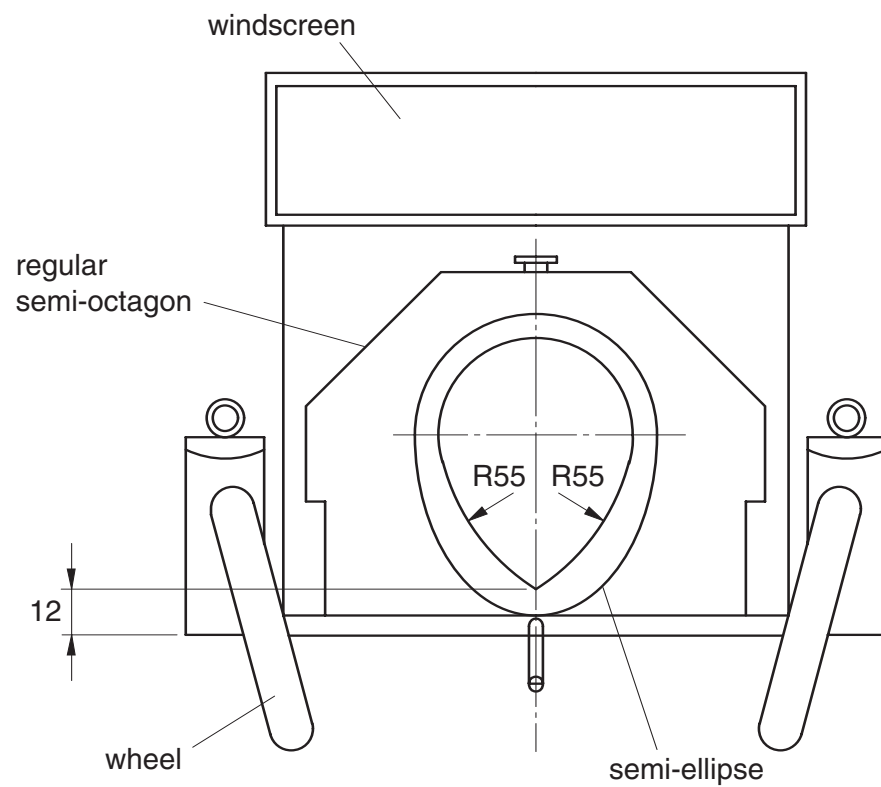
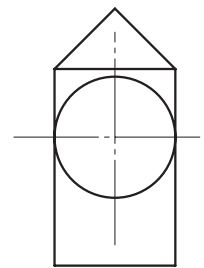

0445/02
0446/02 Specimen Paper 2007 1 hour
 © UCLES 2005 SJF3907/CG T01801/1

Centre Number

Candidate's Number

Candidate's Name

Answer either question B4 or question B5.

B5 The sketch below shows a thin card packaging for a cosmetic product. The packaging has a window so that customers can see the product.

In the spaces indicated:

- (a) draw to a scale of 1:2 in first angle orthographic projection, the view **EV** and the **PLAN** of the dispenser. [10]
- (b) construct, to the same scale, a one-piece development of the packaging. Do not draw the base or any gluing or other flaps. Ignore the thickness of the card. [11]
- (c) sketch a simple support, also made from thin card, which will be inserted in the packaging so that the base of the cosmetic product will be level with the edge **T**. [4]

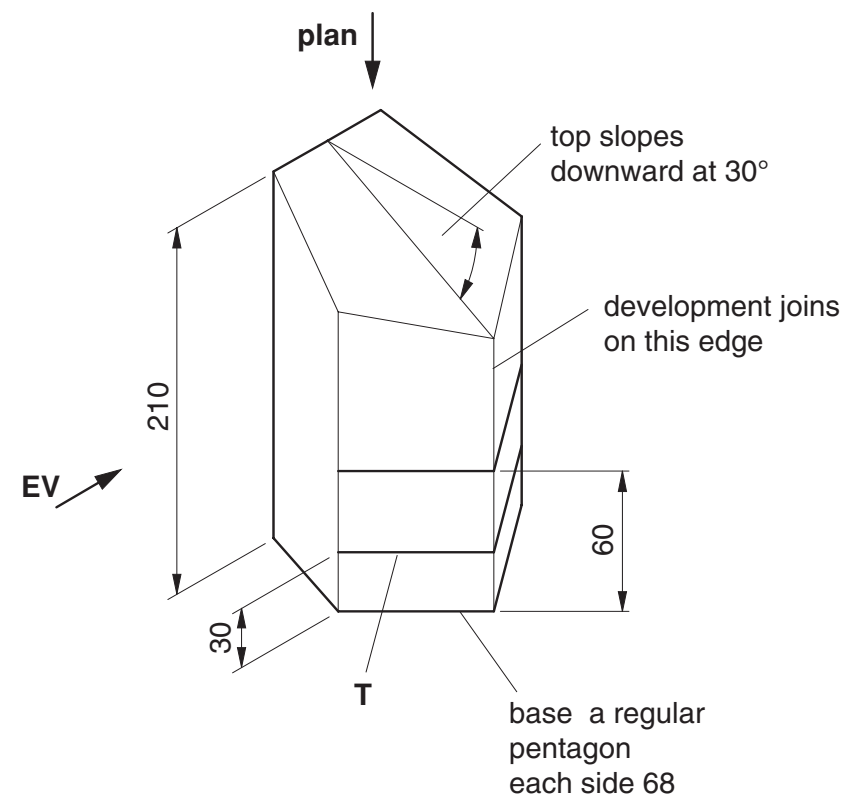

Answer part (a) here.

Answer part (b) here.

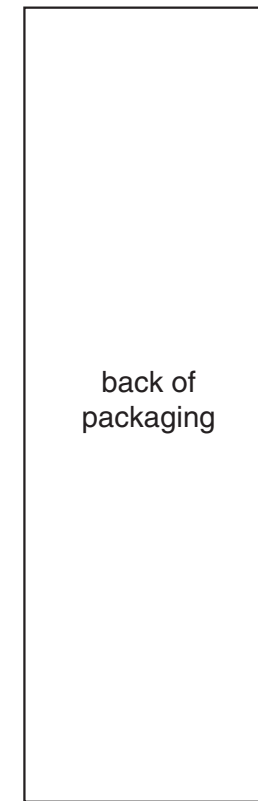

Answer part (c) here.